



***Tier 3/4I Towable Generators
(Trailer and Skid Mounted)***

(Diesel Liquid Cooled)

TS25, 35, 45, 60, 80, 130, 175, 250, 350, 400 and 500

Installation & Operating Manual

**WARNING:
CALIFORNIA PROPOSITION 65 WARNING:**

Engine exhaust from this product contains chemicals known to the state of California to cause cancer, birth defects and other reproductive harm.

**WARNING:
CALIFORNIA PROPOSITION 65 WARNING:**

Battery posts, terminals and related accessories are known to the state of California to cause cancer, birth defects and other reproductive harm.

Table of Contents

Section 1	
Product Safety Information	1-1
Safety Notice	1-1
Responsibility	1-1
IMPORTANT SAFETY INSTRUCTIONS	1-2
Caution Statements	1-6
Section 2	
General Information	2-1
Limited Warranty	2-1
Section 3	
Receiving & Installation	3-1
Receiving & Inspection	3-1
Lifting the Generator	3-1
Physical Location	3-1
Secure the Generator	3-3
Hot Exhaust Gasses	3-3
Installation	3-3
Fuel Connections	3-3
Electrical Connections	3-3
Battery Connections	3-7
Recommended Engine Oil and Battery Type	3-9
Post Installation Checks	3-9
Section 4	
Operation	4-1
Towing the Generator	4-1
Selecting the Proper Towing Equipment	4-1
Safe Driving Tips	4-2
Safety Checks	4-3
Towing Instructions	4-4
Lug Nut Tightness	4-4
Trailer Setup	4-5
Voltage Selection	4-5
Pre-Start Procedure	4-8
Operating Procedures	4-8
Digital Engine Controller Description	4-9
Alarms	4-12
Inputs and Outputs	4-13
Analog Inputs	4-14
Set points	4-14
Section 5	
Troubleshooting and Maintenance	5-1
Maintenance	5-1
Problems and Solutions	5-2
Appendix A	
Wiring Diagrams	A-1
Wiring Diagrams	A-1

Section 1

Product Safety Information

Safety Notice

Be sure that you are completely familiar with the safe operation of this equipment. This equipment may be connected to other machines that have rotating parts or parts that are controlled by this equipment. Improper use can cause serious or fatal injury. Always disconnect all electrical loads before starting the generator.

Installation and repair procedures require specialized skills with electrical generating equipment and liquid cooled engine systems. Any person that installs or repairs this generator must have these specialized skills to ensure that this generating unit is safe to operate. Seek expert advice for repairs or any questions you may have about the safe installation and operation.

The precaution statements are general guidelines for the safe use and operation of this generator. It is not practical to list all unsafe conditions. Therefore, if you use a procedure that is not recommended in this manual you must determine if it is safe for the operator and all personnel in the proximity to the generator and connected loads. If there is any question of the safety of a procedure please seek expert advice before starting or stopping the generator.

This equipment contains high voltages. Electrical shock can cause serious or fatal injury. Only qualified personnel should attempt the start-up procedure or troubleshoot this equipment.

This equipment may be connected to other machines that have rotating parts or parts that are driven by this equipment. Improper use can cause serious or fatal injury. Only qualified personnel should attempt the start-up procedure or troubleshoot this equipment.

- System documentation must be available to anyone that operates this equipment at all times.
- Keep non-qualified personnel at a safe distance from this equipment.
- Only qualified personnel familiar with the safe installation, operation and maintenance of this device should attempt start-up or operating procedures.
- Always stop engine before making or removing any connections.
- Always stop engine and allow it to cool before refueling.

Responsibility

When your generator is delivered, it becomes the responsibility of the owner/operator of the generator set to prevent unsafe conditions and operation of the equipment. Some responsibilities include (but are not limited to) the following:

1. It is the responsibility of the owner/operator of this generator to ensure that this equipment is correctly and safely installed.
2. It is the responsibility of the owner/operator of this generator to ensure that this equipment, when installed fully complies with all federal, state and local codes.
3. It is the responsibility of the owner/operator of this generator to ensure that any person operating this equipment has been properly trained.
4. It is the responsibility of the owner/operator of this generator to ensure that any person operating this equipment has access to all manuals and information required for the safe use and operation of this equipment.
5. It is the responsibility of the owner/operator of this generator to ensure that it is properly maintained and safety inspected at regular scheduled intervals.
6. It is the responsibility of the owner/operator of this generator to ensure that any person who has not been trained on the safe use of this equipment does not have access to this equipment.

Read This Manual Thoroughly

If you do not understand any concept, any procedure, any safety warning statement, any safety caution statement or any portion of this manual, seek expert advice. Make sure you understand the information in this manual so that you can safely enjoy the full use of this generator.

Symbols



This symbol is shown throughout the manual to indicate a connection to ground reference point.



Indicates a potentially hazardous situation which, if not avoided, could result in injury or death.



Indicates a potentially hazardous situation which, if not avoided, could result in injury or death.

Precaution Statements Used In This Manual

There are three classifications of precautionary statements used in this manual. The most critical is a **WARNING** statement, then the **Caution** statement and the least critical is the Note statement. The usage of each statement is as follows:

- WARNING:** Indicates a potentially hazardous situation which, if not avoided, could result in injury or death.
- Caution:** Indicates a potentially hazardous situation which, if not avoided, could result in damage to property.
- Note:** Additional information that is not critical to the installation or operation.

IMPORTANT SAFETY INSTRUCTIONS

SAVE THESE INSTRUCTIONS – This manual contains important instructions for the generator that should be followed during installation, operation and maintenance of the generator.

For ease of reading, the Warning statements are divided into four categories: Operation, Burn, Installation, and Maintenance.

Operation Statements

- WARNING:** If the trailer is not properly secured to the tow vehicles tow hitch, the trailer may separate from the tow vehicle and cause severe injury or property damage. Always ensure that the tow hitch and trailer tongue are properly connected, in good working condition and that safety chains are properly connected from the trailer to the tow vehicle.
- WARNING:** Never allow a person to ride in or on a trailer that is being towed. All states prohibit passengers in towed vehicles. A person can fall off and be struck by another vehicle or run over by the towed trailer. Failure to observe this warning can result in death.
- WARNING:** Before using a tow vehicle, verify that the vehicle is designed for the load. Using a vehicle that is too small is very dangerous. Be certain that it can handle the M.G.V.W. (Maximum Gross Vehicle Weight) and the tongue weight for safe towing and braking.
- WARNING:** For a new trailer, the wheel lug nuts should be tightened to the proper torque specification before use, after 50 miles of operation and every 100 miles of operation thereafter. Failure to check the lug nuts for proper tightness can result in an accident due to a wheel falling from the trailer.
- WARNING:** Never operate a trailer or tow vehicle that has a loose, missing or broken lug nut. The trailer is designed for safe operation with all lug nuts installed and all at the proper torque rating. Operating the trailer with one or more broken or missing lug nuts greatly increases the load on the remaining nuts and can cause failure of the remaining nuts that can result in an accident due to a wheel falling from the trailer.
- WARNING:** Never operate this generator in a manner other than as described in this manual. Operation in any manner not described in this manual should be considered unsafe and should not be attempted. Never start the engine unless you have first verified that the installation and operation of the generator are as described in this manual.
- WARNING:** Be sure that you are completely familiar with the safe operation of this equipment. This equipment may be connected to other machines that have rotating parts or parts that are controlled by this equipment. Improper use can cause serious or fatal injury.
- WARNING:** Exhaust fumes/gases are extremely dangerous and can cause severe illness or death. Never breath exhaust fumes produced by a running engine. Only run the engine outdoors where ventilation is plentiful. Exhaust gases contain carbon monoxide, a colorless, odorless and extremely dangerous gas that can cause unconsciousness or death. Symptoms of carbon monoxide poisoning include: dizziness, nausea, headaches, sleepiness, vomiting or incoherence. If you or anyone else experiences these symptoms, get out into fresh air immediately. Stop the engine and do not restart the engine until it has been inspected and if necessary repaired or reinstalled in a well ventilated area.
- WARNING:** When operating this generator remain alert at all times. Never operate machinery when physically or mentally fatigued, or while under the influence of alcohol, drugs or medication.

Continued on next page.

Operation Statements Continued

- WARNING:** Gasoline and diesel fuel are flammable and can cause fire, explosions, injury or death. For storage or refueling handle fuel with care and only in clean, approved, properly marked safety fuel containers.
- WARNING:** Do not overfill the fuel tank. Only fill the tank to within $\frac{1}{2}$ " of the top of the tank to allow space for fuel expansion. Overfilling of tank may cause fuel to spill out onto engine and cause fire or explosion.
- WARNING:** Clean up fuel spills by wiping completely dry before starting engine. Gasoline and diesel fuel are flammable and can cause fire, explosions, injury or death.
- WARNING:** Make sure the fuel cap is completely and securely closed after refueling to prevent spillage. Gasoline and diesel fuel are flammable and can cause fire, explosions, injury or death.
- WARNING:** Over crank indication can mean a loss of crank disconnect signal during the previous run period. Attempting to restart the engine with no crank disconnect signal can destroy the starter motor, which can cause serious personal injury.
- WARNING:** Hot exhaust gasses must never be directed toward anything that may catch fire or explode.
- WARNING:** This generator must not be used on or near any forest covered, brush covered, or grass covered land unless the engine's exhaust system is equipped with a spark arrestor. The spark arrestor must be maintained in effective working order by the operator.
- WARNING:** Never operate the generator set indoors or in a poorly ventilated area such as a tunnel or cave. Exhaust fumes are extremely dangerous to all personnel that are in or in contact with that area.
- WARNING:** Keep generator at least three feet away from buildings and other structures.
- WARNING:** Keep generator away from flammable or hazardous materials (trash, rags, lubricants, explosives, paints etc.) and grass or leaf build up.
- WARNING:** Some parts of this generator rotate during operation. Rotating parts can present extreme danger if clothing or body extremities are caught by the rotating part and can cause serious or fatal injury. Never touch a part of the generator until the engine has been stopped and all rotating parts are completely stopped. Also, disconnect the battery terminals to prevent accidental engine rotation during servicing.
- WARNING:** Never move a generator set that is running. Loads should be connected and position secure before starting the engine. Hazards are caused by moving a generator set that is running.
- WARNING:** Never connect or disconnect loads during operation. Always connect load circuits before starting the engine and use external branch disconnects etc. to switch loads On/Off.
- WARNING:** High voltage is present whenever engine is running. Electrical shock can cause serious or fatal injury. Never operate electrical equipment while standing in water, on wet ground or with wet hands, feet or shoes or while barefoot.
- WARNING:** High voltage is present whenever the engine is running. Electrical shock can cause serious or fatal injury. Always stop engine before connecting or disconnecting power cords or external devices.
- WARNING:** Be sure that you understand how to stop the engine quickly in case of an emergency situation. Become familiar with the controls and safety systems provided with this generator set.
- WARNING:** Always wear safety glasses with side shields and hearing protection when working near the generator.
- WARNING:** Improper operation may cause violent motion of connected equipment. Be certain that unexpected movement will not cause injury to personnel or damage to equipment.
- WARNING:** Never permit anyone to operate the generator without proper instructions. Be sure to keep a copy of this manual with the generator so that all users can be properly informed of its safe operation.
- WARNING:** Never allow children or pets to be in the area where the generator is running. The generator and the equipment being powered by the generator may cause injury or death.
- WARNING:** Never operate the generator unless all guards, covers, shields and other safety items are properly installed.
- WARNING:** Do not put hands, feet, tools clothing or other objects near rotating parts such as drive shaft, pulley, belt etc. Rotating parts cause extremely dangerous situations because they can catch loose clothing or extremities and cause serious or fatal injury.
- WARNING:** Never operate the engine when the air cleaner is removed. An engine backfire can cause serious burns.

Continued on next page.

Operation Statements Continued

WARNING: Never “jump start” a generator to start the engine. If the battery charge is insufficient to start the engine, charge or replace the battery and try to restart. Jump starting a battery can cause the battery to explode and cause severe injury or death to anyone in the area.

WARNING: Do not smoke near generator during operation or when close to fuel source. Gasoline and diesel fuel are flammable and can cause fire, explosions, injury or death.

WARNING: Keep a fire extinguisher near the generator while generator is in use. An extinguisher rated “ABC” by the National Fire Protection Association is appropriate.

Burn Statements

WARNING: Parts of this generator are extremely hot during and after operation. To prevent severe burns, do not touch any part of the generator until you have first determined if the part is hot. Wear protective clothing and after use allow sufficient time for parts to cool before touching any part of the generator.

WARNING: Do not touch the hot exhaust parts. In addition to a severe burn, the sudden involuntary jerk of the hand or body part caused by contact with high voltage or a hot surface can result in injury to yourself or others.

WARNING: Engine coolant is under pressure and is near the boiling point of water when engine is hot. Do not open the coolant system until the engine has completely cooled. Hot coolant can cause severe burns and other injuries. When engine is cool, coolant level can be checked.

Installation Statements

WARNING: Disconnect the battery’s ground terminal before working in the vicinity of the battery or battery wires. Contact with the battery can result in electrical shock when a tool accidentally touches the positive battery terminal or wire. The risk of such shock is reduced when the ground lead is removed during installation and maintenance.

WARNING: Installation and repair procedures requires specialized skills with electrical generating equipment and small engine systems. Any person that installs or performs repairs must have these specialized skills to ensure that the generator set is safe to operate. Seek expert advise for installation or repairs.

WARNING: Be sure all wiring complies with the National Electrical Code (NEC) and all regional and local codes or CE Compliance. Improper wiring may cause a hazardous condition and exposure to electrical hazards can cause serious injury or death.

WARNING: Be sure the system is properly grounded before applying power. Do not apply AC power before you ensure that grounds are connected. Electrical shock can cause serious or fatal injury. NEC requires that the frame and exposed conductive surfaces (metal parts) be connected to an approved earth ground. Local codes may also require proper grounding of generator systems.

Warning: Do not connect the generator output neutral to the frame or local ground. The generator output is isolated from ground. NEC and local codes require that the generator output remain isolated from local ground reference.

WARNING: Place protective covers over all rotating parts such as drive shaft, pulley, belt etc. Rotating parts cause extremely dangerous situations because they can catch loose clothing or extremities and cause serious or fatal injury.

WARNING: Unauthorized modification of a generator set may make the unit unsafe for operation or may impair the operation of the unit. Never start a generator set that has been modified or tampered with. Be sure that all covers and guards are properly installed and that the unit is safe before starting the engine. If you are unsure, seek expert advise before starting the engine.

WARNING: When moving the generator, use reasonable caution. Be careful where you place fingers and toes to prevent injury “Pinch Points”. Never try to lift a generator without a hoist or lift means because they are heavy and bodily injury may result.

Warning: Never connect this generator to the electrical system of any building unless a licensed electrician has installed an approved transfer switch. The national electrical code (NEC) requires that connection of a generator to any electrical circuit normally powered by means of an electric utility must be connected by means of approved transfer switch equipment to isolate the electrical circuit from the utility distribution system when the generator is operating. Failure to isolate the electrical circuits by such means may result in injury or death to utility power workers due to backfeed of electrical energy onto the utility lines.

Continued on next page.

Installation Statements Continued

WARNING: Circuit overload protection must be provided in accordance with the National Electrical Code and local regulations.

WARNING: Check Ground Fault Circuit Interrupt (GFCI) receptacles monthly by using the “Test” and “Reset” buttons.

WARNING: Have electrical circuits and wiring installed and checked by licensed electrician or qualified technician. Electrical shock can cause serious or fatal injury.

WARNING: Never stand under or close to an object that is being hoisted or lift into position. Accidents happen and if the object falls or tips over you or someone else could be crushed by the weight of the object causing severe injury or death to yourself or others. Always remain a safe distance from the object and always wear protective head gear (hard hat).

Maintenance Statements

WARNING: Installation and servicing of batteries is to be performed or supervised by personnel knowledgeable of batteries and the required precautions. Keep unauthorized personnel away from batteries.

WARNING: Before servicing the generator set, be sure to disconnect the battery terminals to prevent accidental engine rotation or starting.

WARNING: Before cleaning, inspecting, repairing or performing any maintenance to the generator set, always be sure the engine has stopped and that all rotating parts have also stopped. After stopping, certain components are still extremely hot so be careful not to get burned.

WARNING: Before servicing the generator set, be sure to disconnect the glow plugs or spark plug wires and the battery terminals to prevent accidental engine rotation or starting.

WARNING: Engine coolant is under pressure and is near the boiling point of water when engine is hot. Do not open the coolant system until the engine has completely cooled. Hot coolant can cause severe burns and other injuries. When engine is cool, coolant level can be checked.

WARNING: Inspect all wiring frequently and replace any damaged, broken or frayed wiring or wires with damaged insulation immediately. Electrical shock can cause serious or fatal injury.

WARNING: Disconnect all electrical wires and load devices from generator power outlets before servicing the generator. Electrical shock can cause serious or fatal injury. Always treat electrical circuits as if they are energized.

WARNING: A battery presents a risk of fire and explosion because they generate hydrogen gas. Hydrogen gas is extremely explosive. Never jump start a battery, smoke in the area around the battery or cause any spark to occur in the area around the battery.

WARNING: Do not mutilate the battery or dispose of a battery in a fire. The battery is capable of exploding. If the battery explodes, electrolyte solution will be released in all directions. Battery electrolyte solution is caustic and can cause severe burns and blindness. If electrolyte contacts skin or eyes, immediately flush the area with water and seek medical attention quickly.

WARNING: The battery electrolyte is a dilute sulfuric acid that is harmful to the skin and eyes. It is electrically conductive and corrosive. If electrolyte contacts the skin, flush the area immediately with water and wash it off using soap and water. If electrolyte contacts the eyes, immediately flush the eye thoroughly with water and seek medical attention quickly.

WARNING: A battery presents a risk of electrical shock hazard and high short circuit current. Electrical shock can cause serious or fatal injury. Never wear jewelry, watch or any metal objects when in the area around the battery.

WARNING: Check fuel tank, fuel line, and connections monthly for fuel leaks. Diesel is flammable and can cause fire, explosions, injury or death. If a leak is found, replace only with approved pipe or components.

Continued on next page.

Caution Statements

- Caution:** Avoid installing the generator set beside heat generating equipment, or directly below water or steam pipes or in the vicinity of corrosive substances or vapors, metal particles and dust. Heat can cause engine problems to develop and unwanted substances can cause rust or generator failure over time.
- Caution:** Do not apply high voltage to windings (do not start the generator) in a moisture-saturated condition. Moisture can cause insulation breakdown, making it necessary to repair the generator and consequent expense and loss of time.
- Caution:** Use only original equipment or authorized replacement parts. Using the correct parts will assure continued safe operation as designed.
- Caution:** Do not support the generator from the top of the frame or enclosure.
- Caution:** Do not tamper with or change the engine speed. Engine speed is factory set to produce the correct voltage and output frequency.
- Caution:** Never operate the engine without a muffler. The engine is designed to have the correct exhaust components installed and operating without these components can present a fire hazard, cause excessive exhaust gases and cause damage to engine. Inspect muffler periodically and replace if necessary.
- Caution:** The Programmable Output Contacts selection must agree with the external control wiring prior to energizing the controller. Failure to do so may cause severe equipment damage.
- Caution:** If a dead battery is suspected, remove the controller fuse, charge battery (or replace), and then attempting starting. Damage to engine control may result from jump starting.
- Caution:** This generator must have a battery installed for operation. The battery is used during starting and during operation. If engine operation is attempted while the battery is removed, damage to the engine's electrical components may result.
- Caution:** Large "Engine Compartment Doors" on each side of enclosure must remain closed during operation. If doors remain open, engine will overheat due to insufficient air flow around engine.

Section 2

General Information

Thank you for purchasing your Baldor Generator Set. This manual contains information you need to safely and efficiently install and operate your generator set. During the preparation of this manual every effort was made to ensure the accuracy of its contents. This manual describes only very basic engine information. A separate owner's manual for the engine is supplied with this unit for your use. Please refer to the engine manual for information relative to engine operation, maintenance, recommendations and additional safety warnings.

Copyright Baldor © 2006. All rights reserved.

This manual is copyrighted and all rights are reserved. This document may not, in whole or in part, be copied or reproduced in any form without the prior written consent of Baldor Electric Company, Inc.

Baldor Generators have earned the reputation of being high quality and dependable. We take pride in this fact and continue to keep our quality standards high on our list of priorities. We are also constantly researching new technological ideas to determine if they could be used to make our generator sets even better.

Baldor makes no representations or warranties with respect to the contents hereof and specifically disclaims any implied warranties of fitness for any particular purpose. The information in this document is subject to change without notice.

Baldor assumes no responsibility for any errors that may appear in this document.

Limited Warranty

www.baldor.com/support/warranty_standard.asp

Section 3 Receiving & Installation

- Receiving & Inspection** When you receive your generator, there are several things you should do immediately.
1. Observe the condition of the shipping container and report any damage immediately to the commercial carrier that delivered your system.
 2. Verify that the part number of the system you received is the same as the part number listed on your purchase order.
 3. If the system is to be stored for several weeks before use, be sure that it is stored in a location that conforms to published storage temperature and humidity specifications.

WARNING: Never stand under or close to an object that is being hoisted or lift into position. Accidents happen and if the object falls or tips over you or someone else could be crushed by the weight of the object causing severe injury or death to to yourself or others. Always remain a safe distance from the object and always wear protective head gear (hard hat).

Lifting the Generator When lift or hoist equipment is used to lift the generator and move it to position, be careful not to contact overhead wires or other obstacles. Be sure the lift or hoist equipment has appropriate capacity and tires for the terrain to avoid becoming stuck or tipping over. If the shipping pallet is intact, use a fork lift to move the generator. If the shipping pallet has been removed, use the “Lift Point” hole at the top of the generator, Figure 3-1. The lift point is designed only for the weight of the generator and factory trailer. Do not lift by these points if the generator is mounted to a trailer that has been modified from the factory specifications for stock units. Please consult Baldor for custom designs.

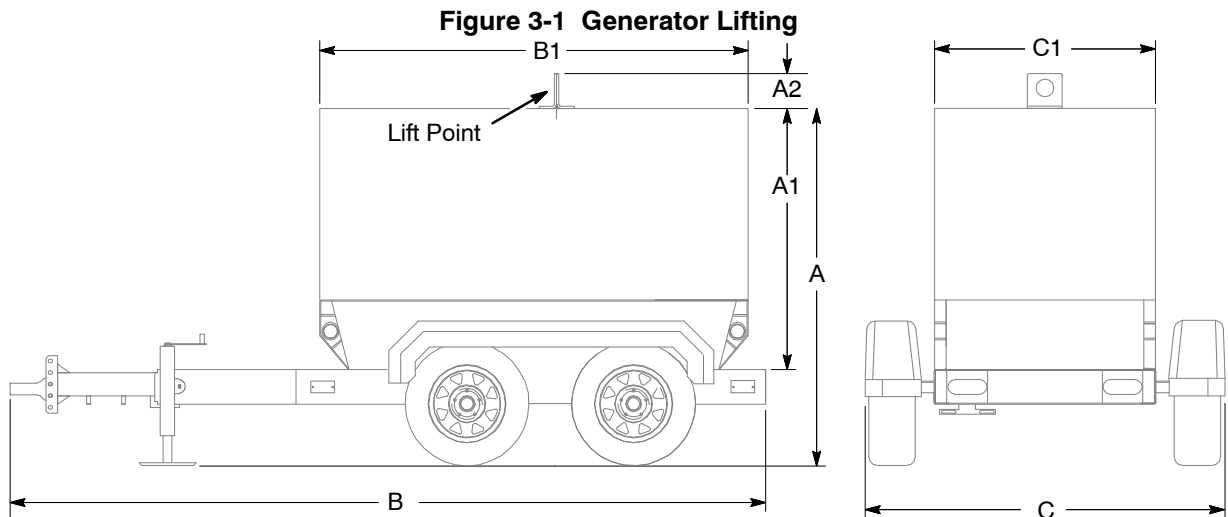

Table 3-1 Mounting Dimensions

Generator	No. of Axles	A	A1	A2	B	B1	C	C1
TS25	1	67	47.5	5.5	130	74	62	38
TS35	1	67	47.5	5.5	130	74	62	38
TS45	2	82	60	5.5	148	84	62	38
TS60	2	82	60	5.5	148	84	62	38
TS80	2	82	80	5.5	148	84	62	38
TS130	2	96	75	5.5	178	118	74	42
TS175	2	97	75	5.5	197	130	74	48
TS250	2	101	78	7.1	233	161	81	55
TS350	2	110	86	7.1	242	170	81	55
TS400	2	120	93	5.22	251	195	98	66
TS500	2	124	97	7.1	251	195	98	66

Physical Location The mounting location of the system is important. It should be installed in an area that is protected from direct harmful gases or liquids, dust, metallic particles, shock and vibration. It should be installed in an outdoor location so the exhaust fumes are vented to the atmosphere.

When the Generator is installed outdoors

The factory installed enclosure is designed to keep out undesirable weather elements while providing cooling and ventilation.

Several other factors should be carefully evaluated when selecting a location for installation:

1. For effective cooling and maintenance, the system should be mounted on a flat, smooth, noncombustible level surface. A concrete pad is ideal and provides a secure installation.
2. Installation should prevent water levels from reaching the generator. Drainage must be adequate to keep concrete pad free from standing water.
3. Installation should prevent obstructions by buildup of leaves, grass, sand, snow, etc. If these items pose a problem, consider building a small fence or other break to protect the unit from accumulation of debris.
4. Installation should place the generator as close as possible to the transfer switch.
5. At least forty-eight (48) inches clearance must be provided on all sides for air flow.
6. Access must be provided to allow the enclosure covers to be opened or removed for service and maintenance.
7. For TS25–TS250, TS400 maximum ambient temperature is 122°F (50°C).
For TS350, TS500 maximum ambient temperature is 113°F (45°C).

Figure 3-2 Generator Mounting (Skid)

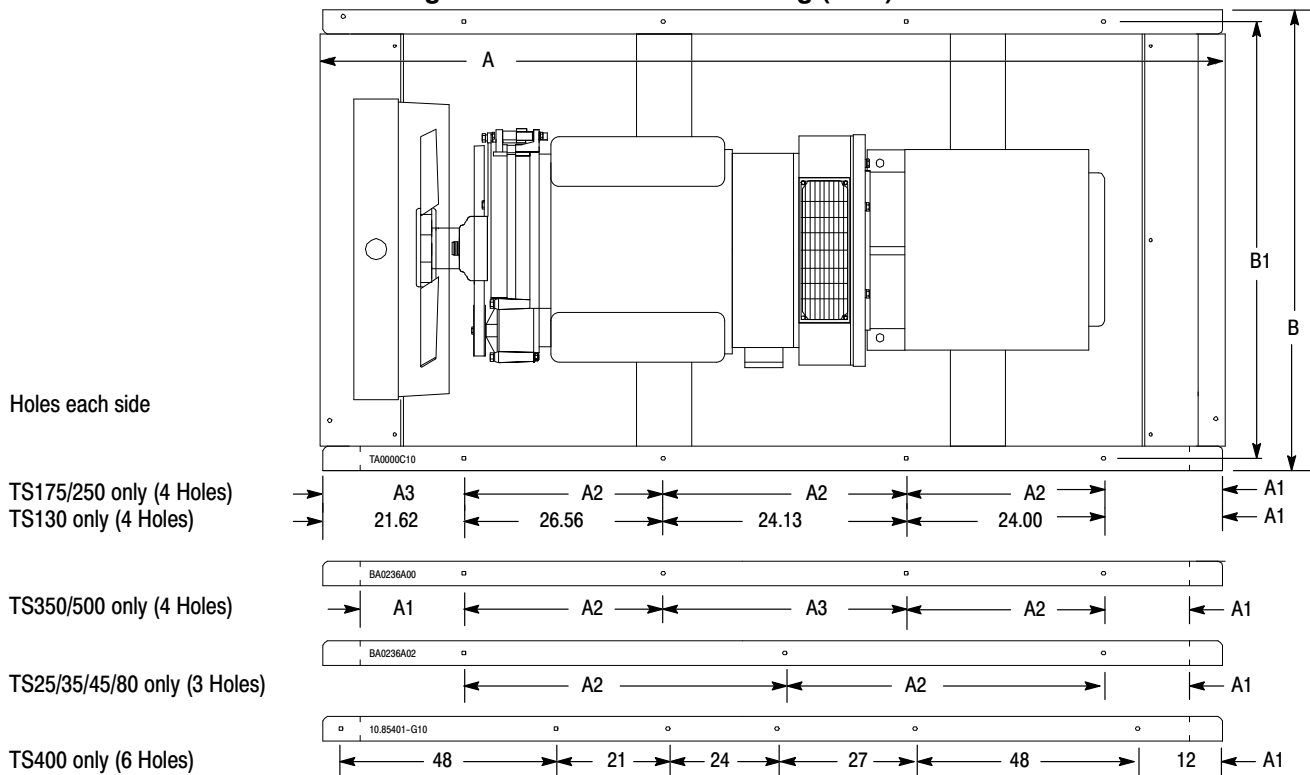

Table 3-2 Mounting Dimensions

Generator	A	A1	A2	A3	B	B1	MTG Hole Dia. in (mm)
TS25	74	13.18	23.81		38	36	0.66 (16.76)
TS35	74	13.18	23.81		38	36	0.66 (16.76)
TS45	84	13.25	28.56		38	36	0.66 (16.76)
TS60	84	13.25	28.56		38	36	0.66 (16.76)
TS80	84	13.25	28.56		38	36	0.66 (16.76)
TS130	118	21.69	See Figure 3-2	See Figure 3-2	42	40	0.75 (19.05)
TS175	130	19.94	30.06	19.88	48	44.74	0.69 (17.52)
TS250	159	21.00	40.00	18.00	54	52	0.75 (19.05)
TS350	168	18.00	44.00		54	52	0.81 (20.74)
TS400	195	12.00	See Figure 3-2	See Figure 3-2	66	63	0.75 (19.05)
TS500	192	12.00	48.00	72.00	66	63	0.63 (16.00)

Secure the Generator (Skid Mount only)

Six mounting bolts (eight for TS130/175/250/350/500, twelve for TS400) in the base frame secure the generator to the shipping pallet. Remove these bolts, lift the generator and remove the shipping pallet. Secure the generator to the concrete pad using anchor hardware (not provided) in the base frame mounting holes (holes are 0.66" diameter). See Figure 3-2 and Table 3-2. Anchor bolts must be long enough to extend through the generator mounting frame.

Hot Exhaust Gasses

WARNING: Exhaust fumes/gases are extremely dangerous and can cause severe illness or death. Never breath exhaust fumes produced by a running engine. Only run the engine outdoors where ventilation is plentiful. Exhaust gases contain carbon monoxide, a colorless, odorless and extremely dangerous gas that can cause unconsciousness or death. Symptoms of carbon monoxide poisoning include: dizziness, nausea, headaches, sleepiness, vomiting or incoherence. If you or anyone else experiences these symptoms, get out into fresh air immediately. Stop the engine and do not restart the engine until it has been inspected and if necessary repaired or reinstalled in a well ventilated area.

WARNING: Hot exhaust gasses must never be directed toward anything that may catch fire or explode.

Exhaust must always be directed away from living areas or buildings that are occupied by people or animals. Never allow exhaust gases to be directed towards any openings or air entry routes (doors, windows, vents, etc...) of an occupied building.

The direction of the discharged hot air and hot exhaust gases is important as they have the potential to create brown spots on the lawn or shrubs. In extreme cases this extremely hot air could cause dried grass, shrubs, trees or other debris to ignite.

It is also recommended that an exhaust rain cap be used whenever it is possible that rain could get into the system. This will help to prevent corrosion and damage to the exhaust system and engine.

Installation

The generator is completely assembled, tested and adjusted at the factory before it is shipped. The procedures presented in this manual are suggestions and it is the responsibility of the Owner/Operator to arrange for these procedures to be performed by licensed contractors according to all applicable codes including local codes for your Municipality/City/County and State. External connections required at the time of installation are:

1. Electrical Connections – power wiring (optional transfer switch) and control wiring.
2. Ground Connection.

After installation, the post installation checks must be performed prior to starting the engine.

After these checks have been performed and the system operation is verified to be good, refer to Section 5 Maintenance for periodic checks that must be performed at scheduled intervals to ensure continued operation with minimal problems.

WARNING: Disconnect the battery's ground terminal before working in the vicinity of the battery or battery wires. Contact with the battery can result in electrical shock when a tool accidentally touches the positive battery terminal or wire. The risk of such shock is reduced when the ground lead is removed during installation and maintenance.

Fuel Connections

External fuel connections are not required. A self contained fuel tank is located within the base of the generator set.

Electrical Connections Class 1 wiring methods must be used for field wiring connections to terminals of a class 2 circuit. It is the responsibility of the owner/operator to arrange for these procedures to be performed by a licensed electrical contractor and ensure conformance to all applicable codes including local codes peculiar to your municipality/city/county and state. Wire size and insulation type should be as required by NEC (National Electrical Code) and local codes.

Warning: Never connect this generator to the electrical system of any building unless a licensed electrician has installed an approved transfer switch. The national electrical code (NEC) requires that connection of a generator to any electrical circuit normally powered by means of an electric utility must be connected by means of approved transfer switch equipment to isolate the electrical circuit from the utility distribution system when the generator is operating. Failure to isolate the electrical circuits by such means may result in injury or death to utility power workers due to backfeed of electrical energy onto the utility lines.

Warning: Incorrect installation of this generator set could result in property damage, injury or death. Connection of the generator to its fuel source must be done by a qualified professional technician or contractor.

WARNING: Be sure the system is properly grounded before applying power. Do not apply AC power before you ensure that grounds are connected. Electrical shock can cause serious or fatal injury. NEC requires that the frame and exposed conductive surfaces (metal parts) be connected to an approved earth ground. Local codes may also require proper grounding of generator systems.

Intended Use The intended purpose of this generator set is to provide electrical power when the main utility power supply is interrupted. Therefore, it is important that all the wiring that connects the generator set with your house, transfer switch, distribution box, battery charger, etc. be properly installed.

Protection Circuit protection is provided within the generator. The power output connections are rated and sized according to the KW of the generator. Proper lead wire from these points to the automatic transfer switch (or load switching device) is mandatory. See transfer switch information for corresponding generator input terminals. Use only copper wires.

Table 3-3 Standby Power Ratings

Generator Catalog No.	Electrical Load Capacity Standby Power Ratings							
	1 Phase				3 Phase			
	kVA	kW	Volts	Amps *	kVA	kW	Volts	Amps
TS25	18	18	240/120	75/2x75	25/25/25	20/20/20	208/240/480	69/60/30
TS35	25	25	240/120	104/2x104	37/37/37	30/30/30	208/240/480	104/90/45
TS45	27	27	240/120	112/2x112	46/48/48	37/38/38	208/240/480	128/114/57
TS60	43	43	240/120	179/2x179	60/61/61	48/49/49	208/240/480	166/146/73
TS80	45	45	240/120	187/2x187	74/80/80	59/64/64	208/240/480	205/192/96
TS130	78	78	240/120	325/2x325	125/127/127	100/101/101	208/240/480	347/301/152
TS175	100	100	240/120	416/2x416	169/188/188	135/150/150	208/240/480	468/450/225
TS250	175	175	240/120	729/2x729	250/250/250	200/200/200	208/240/480	693/601/300
TS350	206	206	240/120	858/2x858	350/350/350	280/280/280	208/240/480	972/842/421
TS400	250	250	240/120	1041/2x1041	400/400/400	320/320/320	208/240/480	1110/962/481
TS500	250	250	240/120	1041/2x1041	500/500/500	400/400/400	208/240/480	1388/1203/601

* Example 2x75 means 2 lines (Line to Neutral) of 120V @ 75 amps each.

Table 3-4 Prime Power Ratings

Generator Catalog No.	Electrical Load Capacity Prime Power Ratings							
	1 Phase				3 Phase			
	kVA	kW	Volts	Amps *	kVA	kW	Volts	Amps
TS25	18	18	240/120	75/2x75	23/23/23	18/18/18	208/240/480	62/54/27
TS35	22	22	240/120	92/2x92	33/33/33	27/27/27	208/240/480	93/81/41
TS45	25	25	240/120	104/2x104	44/44/44	35/35/35	208/240/480	121/105/53
TS60	40	40	240/120	167/2x167	56/56/56	45/45/45	208/240/480	156/135/68
TS80	41	41	240/120	171/2x171	67/73/73	54/58/58	208/240/480	187/174/87
TS130	76	76	240/120	317/2x317	113/115/115	90/92/92	208/240/480	312/277/138
TS175	90	90	240/120	375/2x375	138/156/156	110/125/125	208/240/480	382/376/188
TS250	160	160	240/120	667/2x667	227/227/227	180/180/180	208/240/480	625/541/271
TS350	187	187	240/120	779/2x779	319/319/319	255/255/255	208/240/480	885/767/383
TS400	240	240	240/120	1000/2x1000	365/365/365	292/292/292	208/240/480	1013/878/439
TS500	240	240	240/120	1000/2x1000	455/455/455	365/365/365	208/240/480	1266/1098/549

* Example 2x75 means 2 lines (Line to Neutral) of 75 amps each.

Single Phase Connections

Single phase connections are made at load receptacles located by the operator panel, see Figure 3-3. Simply open the rear panel access door and make the connections. When the panel door is closed, the connections are weather tight.

Figure 3-3 Receptacle Panel (Single Phase)

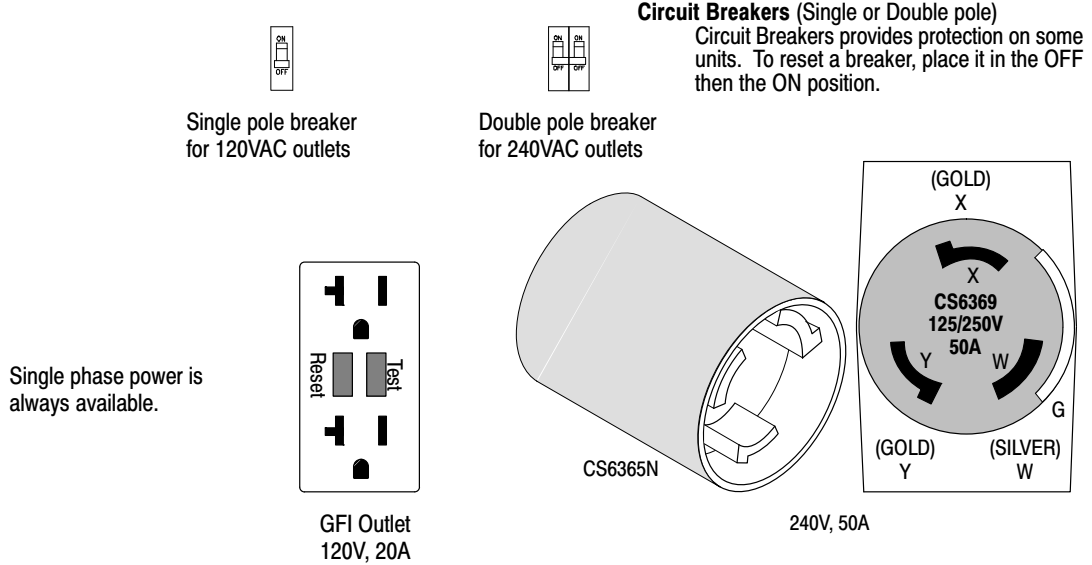
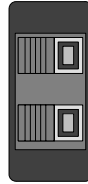

Figure 3-4 Remote Start Connections

Tier 3 Systems



Remote Start Connections on front panel

Three Phase Connections

Three phase connections are made at L1, L2, L3 and N connections shown in Figure 3-5. An interlock trips the breaker if the door is opened during operation.

Figure 3-5 Three Phase Connections

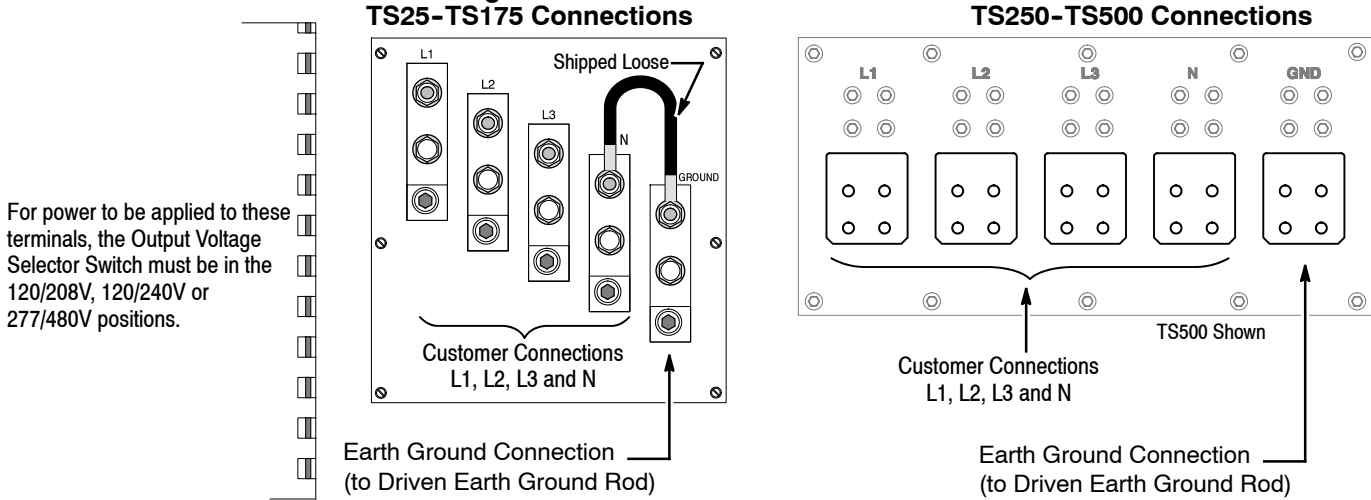

Transfer Switch Considerations

The following are general considerations for the safe use of a transfer switch:

1. The transfer switch should be located inside the building near the main breaker box or the disconnect box.
2. The transfer switch must be kept away from any location that might allow water to get on it.
3. If the transfer switch is mounted outside, it must be protected from the environment and its elements.
4. Do not mount the transfer switch on the generator set.
5. Do not mount the transfer switch where flammable liquids or vapors are present.

Remote Start Contacts

This two-wire connection will start and stop the generator, when properly connected to a remote start contact, shown in Figure 3-4. These contacts are connected to the "Engine Start Contacts" of the automatic transfer switch. A two pole normally open, closed to operate switch may also be used to start the generator.

Shore Power

Use extension cord with appropriately sized conductors to connect the optional "Shore Power" receptacle to 120VAC (240VAC for TS350-TS500) single phase utility power. This powers battery chargers, block heaters etc. when the generator is not in operation. A single phase 20 amp breaker is provided for circuit protection.

AC Input

These connections are for units with float type battery charger or engine block heater. A constant supply of 120 volts AC (or as specified) is needed at these terminals to power these devices when generator is not operating.

Note: Power is not required when the unit is in operation. Internal battery charging and radiant heat during operation eliminate the need for these devices.

Battery Charger Considerations

1. Mount the battery charger inside the generator enclosure as close to the battery as is reasonably possible.
2. Do not mount the battery charger where flammable liquids or vapors are present. When the battery is charging it produces explosive gasses.

General Wiring Considerations

1. When routing the interface wiring, do not route it up against anything that could cut or chafe the wiring. do not route the wire up against any hot or potentially hot object.
2. Make sure that all the electrical components (generator set, transfer switch, battery charger, etc.) share a common ground.
3. Check with your local building inspector to determine what you must do to comply with the local regulations for grounding of this type of permanent installation.

Frame Ground Connection

WARNING: Be sure the system is properly grounded before applying power. Do not apply AC power before you ensure that grounds are connected. Electrical shock can cause serious or fatal injury. NEC requires that the frame and exposed conductive surfaces (metal parts) be connected to an approved earth ground. Local codes may also require proper grounding of generator systems.

It is important for safety reasons that the Generator set, transfer switch and battery charger share a common Ground and neutral.

The NEC requires that the frame and exposed metal surfaces be at local ground reference potential to avoid electrical shock hazard. A local ground reference may require a driven earth ground conductor at the generator installation site. Make the ground connection as shown in Figure 3-5. Use the appropriate size wire as required by NEC and local codes.

1. Open the enclosure electrical access panel door.
2. Connect the ground wire to the “earth ground connection” terminal shown in Figure 3-5. This is the local ground reference to ground the generator enclosure and frame.

Battery Connections The generator is shipped with battery not connected.

Caution: This generator must have a battery installed for operation. The battery is used during starting and during operation. If engine operation is attempted while the battery is removed, damage to the engine’s electrical components may result.

WARNING: Installation and servicing of batteries is to be performed or supervised by personnel knowledgeable of batteries and the required precautions. Keep unauthorized personnel away from batteries.

WARNING: Do not dispose of battery or batteries in a fire. The battery is capable of exploding. If the battery explodes, electrolyte solution will be released in all directions. Battery electrolyte solution is caustic and can cause severe burns and blindness. If electrolyte contacts skin or eyes, immediately flush the area with water and seek medical attention quickly.

WARNING: Do not mutilate the battery . The battery contains electrolyte solution which is caustic and can cause severe burns and blindness. If electrolyte contacts skin or eyes, immediately flush the area with water and seek medical attention quickly.

WARNING: A battery presents a risk of electrical shock hazard and high short circuit current. The following precautions are to be followed when working on batteries:

1. Remove watches, rings, necklaces and all other metal objects.
2. Use tools with insulated handles.
3. Wear safety goggles, rubber gloves and boots.

WARNING: The battery electrolyte is a dilute sulfuric acid that is harmful to the skin and eyes. It is electrically conductive and corrosive. The following precautions are to be followed when working on batteries:

1. Wear full eye protection (safety glasses or goggles) and protective clothing.
2. Where electrolyte contacts the skin, flush the area immediately with water and wash it off using soap and water.
3. Where electrolyte contacts the eyes, immediately flush the eye thoroughly with water and seek medical attention quickly.
4. Spilled electrolyte is to be washed down with an acid neutralizing agent. A common practice is to use a solution of one pound (500 grams) bicarbonate of soda to one gallon (four liters) of water. the bicarbonate solution is to be added until evidence of reaction (foaming) has ceased. The resulting liquid is to be flushed with water and the area dried.

WARNING: A battery presents a risk of fire because they generate hydrogen gas. Hydrogen gas is extremely explosive. Never jump start a battery, smoke in the area around the battery or cause any spark to occur in the area around the battery. The following precautions are to be followed when working on batteries:

1. Do not smoke when near batteries.
2. Do not cause flame or spark in battery area.
3. Discharge static electricity from body before touching batteries by first touching a grounded metal surface.

WARNING: Disconnect the battery's ground terminal before working in the vicinity of the battery or battery wires. Contact with the battery can result in electrical shock when a tool accidentally touches the positive battery terminal or wire. The risk of such shock is reduced when the ground lead is removed during installation and maintenance.

Procedure: The correct type battery must be installed in the battery compartment provided, see Table 3-5. Installation and servicing of batteries is to be performed or supervised by personnel knowledgeable of batteries and the required precautions. Keep unauthorized personnel away from batteries.

1. Open access doors and locate battery tray.
2. Remove battery cables from the battery, the (-) negative first then the (+) positive.
3. Remove the Battery Hold Down Bar and Rods.
4. Remove the old battery and place the correct new battery (see Table 3-5) on the tray.
5. Install the Battery Hold Down Bar and Rods as shown in Figure 3-6.
 - a. Place the bent end of the Battery Hold Down Rod through the hole in the Battery Tray.
 - b. Place the threaded end of the Battery Hold Down Rod through the hole in the Battery Hold Down Bar and secure with flat washer, lock washer and nut.
 - c. Repeat steps a and b for the other Battery Hold Down Rod.

Figure 3-6 Battery Installation

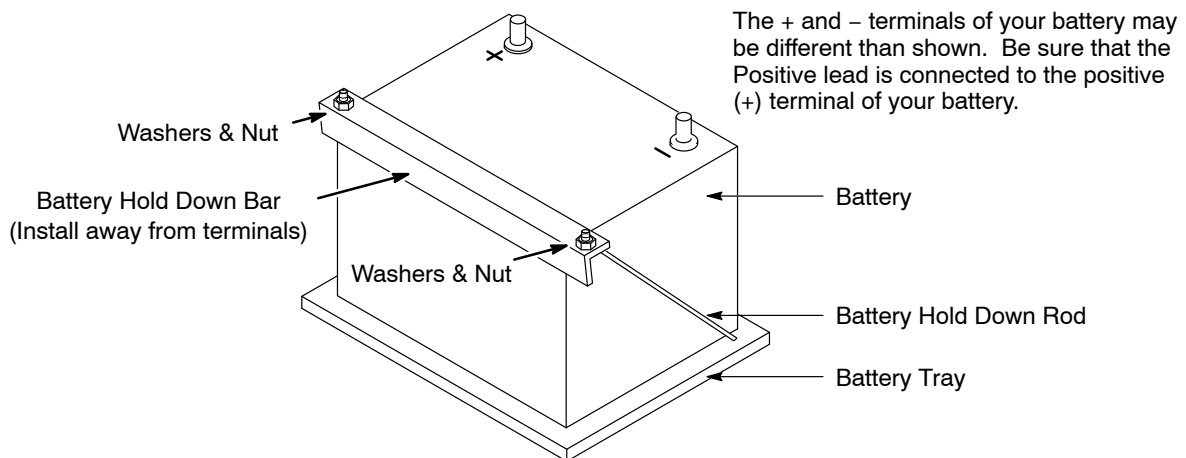

6. Connect the positive lead to the positive (+) battery terminal.
7. Connect the negative lead to the negative (-) battery terminal.
8. Do not lay tools or metal parts on top of batteries.
9. Connect charging source to the battery terminals.
10. Disconnect the battery's ground terminal before working in the vicinity of the battery or battery wires. Contact with the battery can result in electrical shock when a tool accidentally touches the positive battery terminal or wire. The risk of such shock is reduced when the ground lead is removed during installation and maintenance.

Recommended Engine Oil and Battery Type

When replacing batteries, use only the recommended battery for your generator, see Table 3-5.

Table 3-5 Oil & Battery Recommendations

MODEL	SUMMER OIL	WINTER OIL	OIL CAPACITY	RECOMMENDED BATTERY	(AMPS) COLD CRANKING
TS25	SAE. 20W/50	5W/30	5.0 QTS	BCI Group 24	675
TS35	SAE. 20W/50	5W/30	8.5 QTS	BCI Group 24	675
TS45	SAE. 20W/50	5W/30	7.6 QTS	BCI Group 31	925
TS60	SAE. 20W/50	5W/30	7.6 QTS	BCI Group 31	925
TS80	SAE. 20W/50	5W/30	14.7 QTS	BCI Group 31	925
TS130	SAE. 20W/50	5W/30	16.5 QTS	BCI Group 31	925
TS175	SAE. 20W/50	5W/30	34.0 QTS	BCI Group 31	925
TS250	SAE. 20W/50	5W/30	34.0 QTS	BCI Group 31	925
TS350	SAE. 20W/50	5W/30	39.0 QTS	BCI Group 31	(2) 925
TS400	SAE. 20W/50	5W/30	49.0 QTS	BCI Group 31	(2) 925
TS500	SAE. 20W/50	5W/30	69.0 QTS	BCI Group 31	(2) 925

Post Installation Checks

When the initial installation is complete, these checks must be performed before starting the engine. These checks are not required before each start, only after the initial installation.

1. Generators that have been in transit or storage for long periods may be subjected to extreme temperature and moisture changes. This can cause excessive condensation, and the generator windings should be thoroughly dried before bringing the generator up to full nameplate voltage. If this precaution is not taken, serious damage to the generator can result.

Caution: Do not apply high voltage to windings (do not start the generator) in a moisture-saturated condition. Moisture can cause insulation breakdown, making it necessary to return the generator to the factory for repair, and consequent expense and loss of time.

Note: These precautions are especially necessary in locations such as seaboard installations and other high humidity areas. Some installations will be in atmospheres that are much more corrosive than others. Prevention of a failure is better than being forced to make a repair.

2. Verify that the transfer switch is in Utility Power mode. No power must be present at the generator or transfer switch connections. Verify with a voltmeter.
3. Verify that the engine starting battery is disconnected so accidental starting is not possible.
4. Verify generator is securely mounted and anchored to cement pad (skid mount only).
5. Verify that proper clearance exists on all sides and top of enclosure.
6. Verify no debris (buildup of leaves, grass, sand, snow, etc.) is present.
7. Assure generator is a safe distance from any flammable or combustible material.
8. Verify that the three phase generator power (L1, L2, L3 and N) are properly connected to the transfer switch.
9. Verify that the generator and transfer switch load are voltage compatible.
10. Verify that no load is connected to the circuit breaker and/or transfer switch.
11. Inspect the engine and generator and verify that there are no loose wires or components. Tighten if necessary.
12. Verify that the ground conductor is of correct wire size and properly connected.
13. Verify engine oil level is full. Refer to engine manual if necessary.
14. Verify engine coolant level is full. Refer to engine manual if necessary.
15. Verify exhaust system to assure it is in properly connected and pointing away from occupied living space, air entry routes (doors, windows, vents etc.) and combustible materials.

Post Installation Checks Continued

16. Place the voltage output selector switch in the appropriate position.
17. Verify all loads are disconnected.
18. Verify the Master Control is in the “Stop” position.
Connect the engine starting battery to the starter. Verify it is installed correctly.
19. Verify the fuel source is available.
20. Remove all tools, rags, etc. from inside the generator enclosure. Close all enclosure doors and be sure no hands are inside the generator enclosure when it starts.
21. Start the generator.
22. The engine should begin to crank and start when the fuel moves to the engine. If the engine fails to start, refer to Section 5 Troubleshooting.
23. With the engine running, several checks must be made:
 - a. Verify there are no fuel leaks. If a fuel leak is detected, stop the engine (set the Master Control in the “Stop” position) immediately and repair the leak before proceeding.
 - b. Verify there are no coolant or oil leaks. If a leak is detected, stop the engine (set the Master Control in the “Stop” position) immediately and repair the leak before proceeding.
 - c. Verify that operation is smooth. If squeals, vibrations or other abnormal sources of noise exist, stop the engine (set the Master Control in the “Stop” position) immediately and repair before proceeding.
 - d. Verify the correct voltage exists at the receptacles.

WARNING: Engine coolant is under pressure and is near the boiling point of water when engine is hot. Do not open the coolant system until the engine has completely cooled. Hot coolant can cause severe burns and other injuries. When engine is cool, coolant level can be checked.

24. After the operation checks are made, stop the engine (set the Master Control in the “Stop” position) and wait 2 hours for the engine to cool. When the engine is cool, check engine oil and coolant levels as instructed in the engine operation manual.
25. Close all enclosure covers. The post installation checks are now complete.

Section 4 Operation

Towing the Generator

- WARNING:** Never allow a person to ride in or on a trailer that is being towed. All states prohibit passengers in towed vehicles. A person can fall off and be struck by another vehicle or run over by the towed trailer. Failure to observe this warning can result in death.
- WARNING:** Before using a tow vehicle, verify that the vehicle is designed for the load. Using a vehicle that is too small is very dangerous. Be certain that it can handle the M.G.V.W. (Maximum Gross Vehicle Weight) and the tongue weight for safe towing and braking.
- WARNING:** For a new trailer, the wheel lug nuts should be tightened to the proper torque specification before use, after 50 miles of operation, after 100 miles of operation and periodically thereafter. Failure to check the lug nuts for proper tightness can result in an accident due to a wheel falling from the trailer.
- WARNING:** Never operate a trailer or tow vehicle that has a loose, missing or broken lug nut. The trailer is designed for safe operation with all lug nuts installed and all at the proper torque rating. Operating the trailer with one or more broken or missing lug nuts greatly increases the load on the remaining nuts and can cause failure of the remaining nuts that can result in an accident due to a wheel falling from the trailer.
- Make sure the tow vehicle is able to tow the load. Vehicle brake capacity is extremely critical and the tow vehicle must be able to handle the additional weight of the trailer mounted generator. Radiator and transmission cooling must also be considered.
 - Be sure hitch capacity is equal to or greater than the load when mounted on the vehicle.
 - Be sure the size and rating of the hitch ball is equal to or greater than the load.
 - Make sure the safety chain(s) rating is equal to or greater than twice the maximum gross vehicle weight rating of your trailer.
 - It is illegal to transport passengers in any trailer.
 - Reduce weight in car trunk and rear seat areas by the amount of tongue weight of your trailer.
 - Any alterations or changes made to the trailer void any express or implied warranties on the trailer or towing equipment.

Selecting the Proper Towing Equipment

When selecting the proper towing equipment, the two most important factors that must be considered are the M.G.V.W. (Maximum Gross Vehicle Weight) and the Tongue Weight (trailer tongue weight at the hitch). The M.G.V.W. is the total weight of the trailer plus the payload in the trailer. The tongue weight is the downward pressure exerted at the coupler. The easiest way to measure the gross vehicle weight is to place the loaded trailer on a vehicle scale making sure that the scales are supporting the entire weight of the loaded trailer.

The easiest method to measure tongue weight is to place the jack stand (trailer tongue) on a scale making sure the trailer is level. The trailer tongue should be level and in its normal towing position. Tongue weight should be 10% of trailer weight and not more than 10% of M.G.V.W.

Tow Vehicle

Make sure the vehicle you are using to tow the trailer is capable of towing the weight. Check the vehicle Owner's Manual for towing capability of the towing vehicle or contact the vehicle manufacturer for this information. Make sure the tow vehicle is able to tow the load. Vehicle brake capacity is extremely critical and the tow vehicle must be able to handle the additional weight of the trailer mounted generator. Radiator and transmission cooling must also be considered. Seek expert advice to select the proper tow vehicle. Trailers with a gross vehicle weight rating that exceeds 10,000 lbs require special consideration.

Table 4-1 Tow Hitch Capacity

Tow Vehicle	Hitch Class	Maximum Tow Capacity	Maximum Tongue Weight
Compact Vehicle	Sub Class I	1000 Lbs.	100 Lbs.
Compact Vehicle	Class I	2000 Lbs.	200 Lbs.
Mid & Full Size Vehicle	Class II	3500 Lbs.	300 Lbs.
3/4 Ton or larger Truck	Class III	5000 Lbs.	500 Lbs.
1 Ton or larger Truck	Class IV	10000 Lbs.	1000 Lbs.
Class 3-8 Vehicle	Custom Engineered	Custom Engineered	Custom Engineered

Selecting the Proper Towing Equipment Continued

Electrical Trailer Wiring

All trailers must have taillights, brake lights and turn signals connected to the towing vehicle's electrical system. It is also recommended that a heavy duty turn signal flasher and emergency flasher (if separate) be installed since the trailer lights place an extra load on car flasher units.

Towing Heavy Trailer Loads

1. Trailer brakes. In all cases refer to your vehicle's owner manual and the trailer operating manual to be certain you have an adequate braking system to handle the vehicle/trailer combination. Also, State and local requirements, road and weather conditions and grade of road, etc. should be considered for trailer braking.
2. Additional equipment. The following items may be helpful for towing heavy loads. Consult your vehicle's owner manual or dealership for recommended towing accessories.
 - a. Overload Springs
 - b. Overload or air shocks
 - c. Transmission Oil Cooler
 - d. Engine Oil Cooler
 - e. Coolant recovery System
 - f. Heavy Duty Fan
 - g. Side View Mirrors
 - h. Sway Control

Safe Driving Tips

1. Loading Trailer. The trailer should be loaded so that the downward tongue weight is approximately 10% of the gross vehicle weight. The trailer tongue should be level with the tow vehicle coupling during towing. Adjust load, hitch and coupling as necessary to ensure trailer tongue remains level during towing.
2. Following and stopping distance. The stopping distance is increased when towing a trailer. A rule of thumb for the minimum distance that should be maintained between you and the preceding car on dry pavement is one car and trailer length (2 car lengths) for every 10 MPH you are traveling. The distance should be increased accordingly depending on road and weather conditions. Avoid sudden stops if possible.
3. Passing. Accelerating and passing should be done slowly to allow extra distance for passing. Signal well in advance when passing and returning to the proper lane. Allow for the extra length of the trailer before changing lanes. Never change lanes abruptly as this may cause the trailer to sway and push the tow vehicle into a "jack knife" condition.
4. Turning. Allow for the extra length of the trailer. Drive slightly beyond normal turning point to avoid running over curbs and soft shoulders. Turning radius increases when towing.
5. Uphill and Downhill Grades. Reduce speed and use a lower transmission gear for steep or long up or down hill grades. Maintain safe distance from other vehicles.
6. Parking.
 - Avoid parking on uphill or downhill grades
 - Place transmission in "PARK"
 - Apply parking brake.
 - Use wheel chocks.
 - In a parking lot, avoid parking close to other vehicles. Turning radius is greater and it may be impossible to get out of a parking space after a few other vehicles have parked around your vehicle.
7. Trailer Sway. If trailer sway occurs, reduce speed. Apply trailer brakes rather than car brakes to control sway. See step 1 and ensure trailer tongue remains level during towing. If sway persists, seek expert advise.
8. Trailer Backing. Backing a trailer can be frustrating. The most important item to remember is that the trailer will go in the opposite direction of the tow vehicle. It is helpful to have another person help you back the trailer and watch for objects. Turn the vehicle's wheels to the right to make the trailer go left, and vice versa. Put your hand at the bottom of the steering wheel. The trailer will go in the same direction your hand moves (moving your hand to the right will cause the trailer to go right, and vice versa). Sharp steering wheel corrections will cause the trailer to jackknife and may cause damage to the rear of the tow vehicle or the front of the trailer.

Figure 4-1 Trailer Component Identification

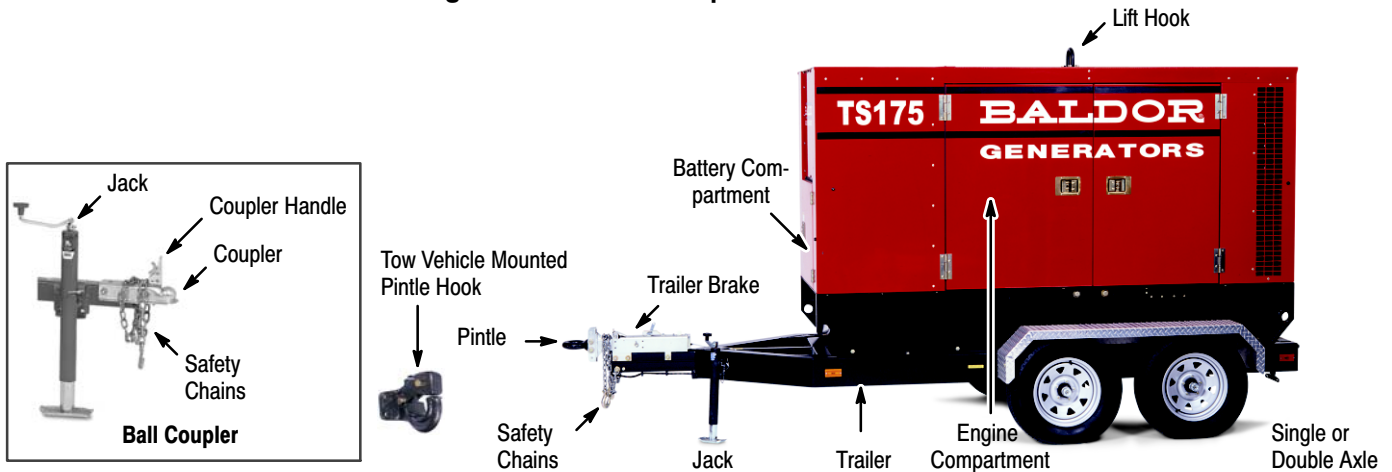

Caution: Large “Engine Compartment Doors” on each side of enclosure must remain closed during operation. If doors remain open, engine will overheat due to insufficient air flow around engine.

WARNING: If the trailer is not properly secured to the tow vehicles tow hitch, the trailer may separate from the tow vehicle and cause severe injury or property damage. Always ensure that the tow hitch and trailer tongue are properly connected, in good working condition and that safety chains are properly connected from the trailer to the tow vehicle.

Safety Checks The following items should be checked before each use and once every 100 miles of towing:

1. Verify the tow vehicle is designed to tow the trailer before trailer is connected to the vehicles hitch. Using a tow vehicle that is too small is very dangerous.
2. Verify the stop, tail and turn signals are working properly. Replace damaged lenses, reflectors or bulbs.
3. Check wires for good connections and possible fraying or wearing of insulation.
4. Check and properly maintain the trailer, hitch, jack, ball and coupler.
5. Inspect hitch and ball for damage. Ball or hitch can be damaged in parking, hitting curbs, dragging when crossing ditches or railroad tracks.
6. Check and properly tighten all bolts on trailer, hitch, ball and coupler (including trailer wheels).
7. Check safety chains for wear and do not allow them to drag on ground or roadway.
8. Test breakaway system.
Hydraulic surge brake system, normally have a cable or chain connected to the tow vehicle. In a break away condition, this cable or chain activates the master cylinder and operates the brakes as the trailer stops.
An electric brake system, the emergency breakaway system has a battery, charger, breakaway switch with a pull pin and cable connected to the tow vehicle. In a break away condition, this cable operates the electric brakes (power provided by the brake battery) as the trailer stops.
9. Check all generator mounting hardware for tightness.
10. Check tow vehicle tires for wear and proper inflation. (Check vehicle’s owner manual for proper level of inflation of tires for towing a trailer).
11. Check trailer tires for wear and proper inflation. Replace only with a tire of the same size and capacity ratings.
12. Carry emergency flares, reflectors and fire extinguisher.
13. Carry spare light bulbs and fuses.
14. Wheel bearings should be checked and regreased after the first 100 miles, and every 4000 miles thereafter or at least once a year. Wheel bearing grease or a good grade of multi-purpose grease should be used for packing wheel bearings. If you don’t know how to repack your wheel bearing, take your trailer to a service shop. Be sure to properly tighten the axle nut and wheel nuts during assembly.
15. For proper tow vehicle maintenance while towing a trailer, check vehicle’s owner manual and manufacturer’s specifications.

Towing Instructions

See Figure 4-1 for component identification.

1. Be sure the generator is off.
2. Shut all enclosure doors and latch the locks.
3. Back the tow vehicle to within a few inches of the trailer coupler (Pintle or Ball).
4. Be sure the Coupler Handle is in the “UP” (open) position or the Pintle Hook is Open.
5. Adjust the trailer jack for the height of the hitch on the tow vehicle.
6. Back the tow vehicle so the trailer coupler is directly over the tow vehicle ball hitch or the Pintle hook.
7. Lower the trailer so the trailer coupler rests securely on the ball hitch of the tow vehicle. Move the Coupler Handle to the horizontal position and lock it in place to securely hold the ball hitch of the tow vehicle.

OR

Latch the Pintle and lock the Pintle device securely.

Note: If this is not done properly, the trailer may become unhitched when it is towed.

8. Retract the front jack, pull the jack pin and rotate the jack 90 degrees from vertical to the horizontal position, making sure the self-locking pin reseats and the jack is secured to the tow bar (stowed position).
9. Connect safety chains, making sure to cross them. If a safety chain is too long, simply twist it a few turns to shorten the chain before attaching to the tow vehicle.
10. Connect the trailer light connector to the tow vehicle.
11. Test the trailer lights to ensure they are operational.
12. Check tires for proper inflation.
13. Check wheel lug nuts for correct tightness (see Lug Nut Tightness). Wheel nuts/bolts should be torqued before the first road use and after each wheel removal. Check and re-torque after the first 50 miles and again at 100 miles. Check periodically thereafter.
14. Verify that all jacks, pins, cables, and doors are secured and trailer tongue is level.
15. Remove tire chocks (if used). These prevent the trailer from moving when parked.

Lug Nut Tightness

Be sure to use only the fasteners matched to the cone angle of your wheel (usually 60 or 90 degrees.) The proper procedure for attaching your wheel is as follows, see Figure 4-2:

1. If a wheel is removed and installed, start each nut by hand to prevent cross threading.
2. Tighten lug nuts in the following sequence.
 - a. Tighten each bolt in the sequence shown in Figure 4-2 and tighten to one half the torque specified until all lug nuts are tightened to one half the torque.
 - b. Tighten each bolt in the sequence shown in Figure 4-2 and tighten to three fourths the torque specified until all lug nuts are tightened to three fourths the torque.
 - c. Tighten each bolt in the sequence shown in Figure 4-2 and tighten each to the specified torque until all lug nuts are tightened to the correct torque.

Figure 4-2 Lug Nut Tightening Specifications

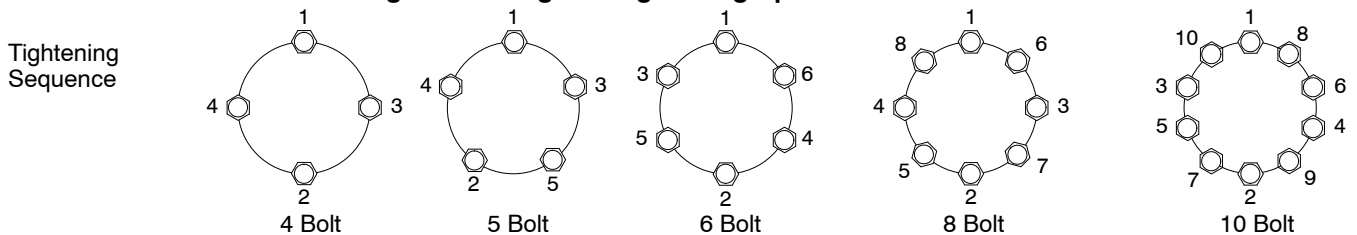

Torque Specification

Description	Application	Minimum Torque (ft-lbs.)	Maximum Torque (ft-lbs.)
1/2" Cone nut	12" – 13" Wheel	50	65
	14" – 16" Wheel	90	120
5/8" Cone nut	Flat Disc Wheel	175	225
5/8" Cone nut	Clamp Ring	190	210
3/4" Hex nut	Demountable Ring Clamp	210	260

Trailer Setup

See Figure 4-1 for component identification. Carefully read all instructions before starting.

1. Locate a suitable, level location. Also be sure there are no overhead wires or obstructions.
The trailer is balanced so the majority of the weight rests on the tow bar (Jack). If on a minor incline, the safest way to position the trailer is to have the tow bar facing down the incline (front of the trailer lower than the rear of the trailer).
2. Install tire chocks if used. These prevent the trailer from moving when parked.
3. Disconnect the safety chains and the trailer light connector from the tow vehicle.
4. Pull the pin on the front jack and rotate the jack 90 degrees to the vertical position. Lock the jack in the vertical position using the pin to secure it.
5. Move the Coupler Handle to the vertical position to release the ball hitch.
OR
Release the Pintle hook.
6. Use the jack to raise the trailer coupler from the ball hitch of the tow vehicle.
7. The tow vehicle can now be moved away from the trailer.
8. Use the jack to level the trailer for operation.

Voltage Selection

WARNING: High voltage is present whenever the engine is running. Electrical shock can cause serious or fatal injury. Always stop engine before connecting or disconnecting power cords or external devices.

WARNING: High voltage is present whenever engine is running. Electrical shock can cause serious or fatal injury. Never operate electrical equipment while standing in water, on wet ground or with wet hands, feet or shoes or while barefoot.

Hard Wire Load Terminal Block, shown in Figure 3-5.

1. Ensure the generator is off.
2. Place voltage select switch in the correct position 208/120, 240/120 or 480/277VAC. Refer to Table 4-2 for voltages available in each position. To ensure the switch position is not accidentally changed, it should be padlocked as shown in Figure 4-3.

Figure 4-3

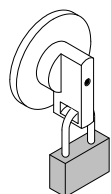

Insert padlock through the hole in the handle. This activates an internal mechanism that prevents handle rotation.

3. Carefully inspect all Individual load cables for broken insulation or other signs of damage. Never use a damaged cable. Replace it before usage.
4. L1, L2, L3, Neutral and Ground cables must be brought into load block compartment through access hole in base of enclosure.
5. Ensure that wires are properly connected and connections are secure.
6. Use disconnect at the load to turn off the load. Do not start engine with load switched "on". Allow engine to come up to speed and warm up before load is switched on.

Note: When the generator is running, opening load block door will cause load disconnect to trip.

7. Observe the output voltage indicator and set the Voltage Adjust (Figure 4-5) for proper voltage.
8. If left unattended, lock all doors to prevent tampering or injury.

Table 4-2 Three/Single Phase Operation

Switch Position	Alternator Winding Connection	Voltage Adjust Position	Voltage at Terminal Lugs						Voltage at Plug Receptacles		
			Line To Line Voltage			Line To Neutral Voltage			120VAC Receptacles	240VAC Receptacles (Twist Lock)	
			L1-L2	L2-L3	L1-L3	L1-N	L2-N	L3-N	L-N	L-L	L-N
480/277	Series High Wye	Minimum	416	416	416	240	240	240	120	208	120
		Middle	460	460	460	266	266	266	133	230	133
		Maximum	480	480	480	277	277	277	139	240	139
208/120	Parallel Low Wye	Minimum	208	208	208	120	120	120	120	208	120
		Middle	230	230	230	133	133	133	133	230	133
		Maximum	240	240	240	139	139	139	139	240	139
240/120	Parallel Low ZigZag	Minimum	Ⓛ	Ⓛ	200	100	Ⓛ	100	100	200	100
		Middle	Ⓛ	Ⓛ	220	110	Ⓛ	110	110	220	110
		Maximum	Ⓛ	Ⓛ	240	120	Ⓛ	120	120	240	120

Ⓛ No connection at Terminal Lug #2.

Receptacle Panel Load Connections, see Figure 4-4.

- 240/120VAC voltage is present at the receptacle panel at all times when generator is running.
- Carefully inspect all Individual load cables for broken insulation or other signs of damage. Never use a damaged cable. Replace it before usage.
- Individual load cables may be routed into the receptacle compartment through the Enclosure Electrical Access Panel.
- Individual load cables may be connected or disconnected while generator is running. Use extreme care not to touch any electrical wire or terminal to avoid shock hazard.
- Keep Enclosure Electrical Access Panel closed at all times. This prevents rain or other harmful elements from entering the compartment. Output metering and gages can be observed through the window in the Enclosure Electrical Access Panel.

Figure 4-4 Receptacle Panel (Single Phase)

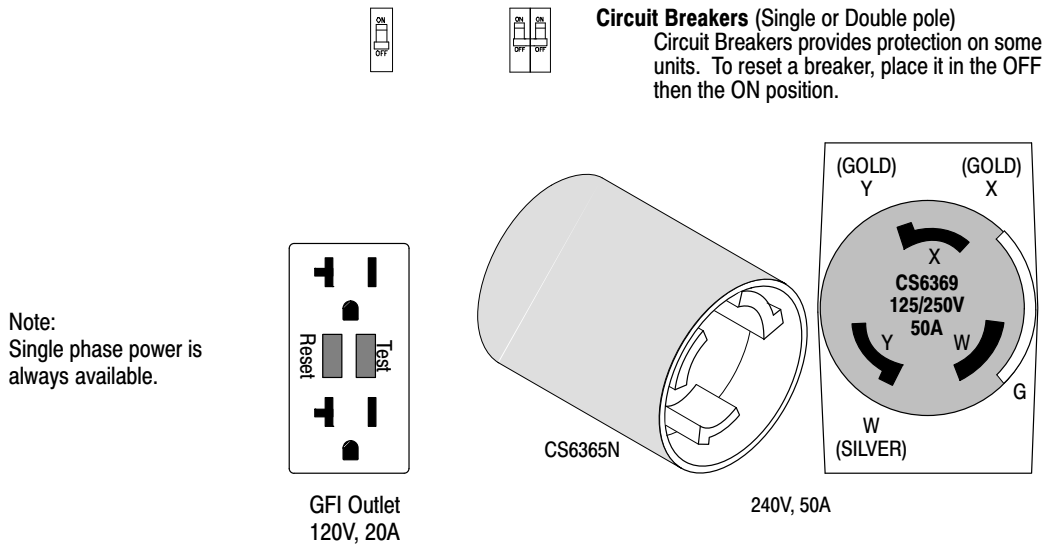

Circuit Breakers (Single or Double pole)
Circuit Breakers provides protection on some units. To reset a breaker, place it in the OFF then the ON position.

Meters, switches, lights and other operator control components are located in various places on each panel. Figure 4-5 can be used to identify the function and features of each operator control regardless of where it is located on your panel.

Figure 4-5 Operator Control Panel Components

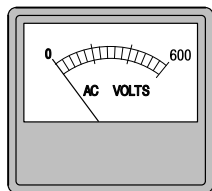

Volts
Analog display of generator output voltage in RMS volts.

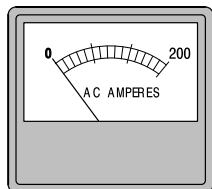

AMPS
Analog display of generator output current in RMS amps.

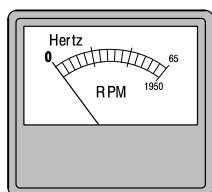

HERTZ
Analog display of generator RPM which relates to the output frequency in Hertz.

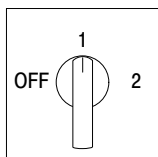

Amps Switch switch (On-Off)
Selects what is displayed on AC Amperes meter.
Off – No AC Ampere display.
1 – Phase 1 current display.
2 – Phase 2 current display.
3 – Phase 3 current display.

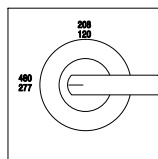

Voltage Select Switch switch
Selects 208/120, 240/120 or 480/277VAC.



BREAKER
or

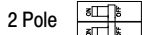

Breaker Circuit Breakers provides protection on some units. To reset a breaker, simply press the center button when tripped or move handle to "Off" then back to "On".

Note: Some features are optional and may not be installed on your system.

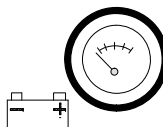

Battery
Displays the voltage of the engine starting battery.

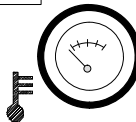

Water Temp
Displays the temperature of the engine coolant.

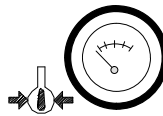

Oil Press
Displays engine oil pressure.



Horn A Horn (annunciator or buzzer) sounds an alarm when operator attention is needed.



Shore Power Inlet Connect an extension cord that has an appropriate rating from utility power to this outlet. To power onboard battery charger, block heater, etc.



Voltage Adjust
Increase or Decrease the Generator output voltage.



Panel Lights)
Lamps to illuminate the operator panel.

PANEL LIGHTS



Panel Lights switch (On-Off)
Turns on the panel lights.

FUSE



Fuse Fuses provides protection on some units. (Do not remove while generator is running).



Auto Start Connection for external two wire starting from transfer switch or other controller. Strip the insulation from the remote start wires. Simply press while inserting the wire then release to secure the connection.

Voltage Reconnect and Adjustment

The digital engine controller runs software called voltage auto-detect. Every time the engine is started and after the timer in the Engine Params: Stabil Time has elapsed, the nominal voltage will be detected and locked in. Various set points in the engine controller are then calculated as a percentage of this nominal voltage. For example: The over-voltage set point is set to 110%. This means that when the unit is providing 208V, the over-voltage set point will lock in at 229V. When the unit is operating in 480V the over-voltage set point will lock in at 528V.

Example: To change the voltage from 208V nominal to 240V nominal, the voltage adjustment must be made before the controller locks in the nominal voltage.

1. Set the Voltage Select Switch to 240/120V position.
2. Start the engine.
3. Immediately adjust the Voltage Adjust for 240VAC nominal before the 20 second timer expires.
4. The new 240V nominal voltage is now locked in.

This procedure must be performed whenever the nominal voltage is changed.

Pre-Start Procedure

Before attempting to start the generator set, several things must first be verified or performed. These are:

1. Fill system fuel tank with clean, fresh diesel fuel.
2. Fill engine crankcase to full mark with clean, fresh lubricating oil per engine manufacturer operating guide.
3. Radiator coolant should be checked at the beginning of each day and filled in compliance with the engine manufacturer's guidelines.
4. Secure the generator for operation.
 - a. Skid mounted – the power generating system should be mounted to a smooth, hard surface suitable for supporting the system under all stress conditions.
 - b. Trailer mounted – block wheels to prevent accidental movement. Use jack (Figure 4-1) to level the generator.
 - c. Adequate clearance must be provided for access doors to fully open.

Note: The exhaust also exits radiator end. When positioning a generator system ensure position does not cause a concentration of toxic emissions.

5. Place voltage select switch in the correct position 208/120, 240/120 or 480/277VAC and pad lock it in position if required (Figure 4-3).
6. Carefully inspect all Individual load cables for broken insulation or other signs of damage. Never use a damaged cable. Replace it before usage.
7. L1, L2, L3, Neutral and Ground cables must be brought into load block compartment through access hole in base of enclosure.
8. Ensure that wires are properly connected and connections are secure.
9. Ensure that an external ground connection is made when required for safety.
10. Ensure that the Remote Start wires are properly connected, if used.
11. Use disconnect at the load to turn off the load. Do not start engine with load switched "On". and warm up before load is switched on.
12. Manually start the engine, allow engine to come up to speed and perform the Voltage Reconnect and Adjustment within the allotted time.
13. Stop the engine.

Caution: Large "Engine Compartment Doors" on each side of enclosure must remain closed during operation. If doors remain open, engine will overheat due to insufficient air flow around engine.

14. Ensure that Engine Compartment doors are closed for proper ventilation.

Note: Receptacle Panel Load cables may be routed into the receptacle compartment through the Enclosure Electrical Access Panel after generator is started and has warmed up.

Operating Procedures The engine-generator controller is designed to start and stop an engine from either AUTO "Automatic" mode or Manual "NOT IN AUTO". Refer to Figure 4-6.

Manual Start Procedure

1. Press PAGE until the "OFF AUTO MAN" display is shown.
2. Press Mode▶ until control is in MAN mode.
3. Press "Start".
4. The controller will start the engine.

Manual Stop Procedure

1. Use disconnect at the load to turn OFF the load. Allow generator cool down if needed.
2. Press "Stop". Press Mode▶ until control is in OFF mode.

AUTO Start Procedure

1. Press Mode▶ until control is in AUT mode.
In Auto mode, the generator will start when the remote start input closes.
2. In Auto mode, the generator will stop when the remote start input opens.

Figure 4-6 Operator Control Panel

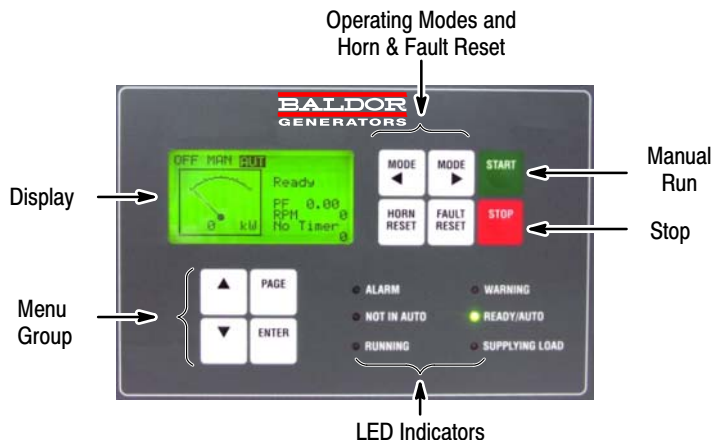

Note: The operator control panel is equipped with a heater element that allows the LCD display to operate to -40°C (not the entire generator set, see generator specifications). This heater operates from the main battery power.

LED Indicators

- Alarm (red) – Alarm (shutdown) condition occurred. Annunciates & shuts down generator.
- Not In Auto (red) – Control is not in auto mode and cannot provide standby power.
- Running (green) – Generator is running, no alarms or warnings.
- Warning (yellow) – A warning condition has occurred. Annunciates only.
- Ready/Auto (green) – Control is in Auto mode and ready to provide standby power.
- Supplying Load (green) – Generator is providing output voltage to load.

Table 4-3 Alarm & Warning Conditions

Alarm	Warning	
X	X	High Coolant temperature
X	X	Low Oil pressure
X	X	Low Fuel level
X	X	Generator Under/Over Voltage
X	X	Generator Under/Over Frequency
X	X	Generator Over Current
X		Generator Overspeed
	X	Coolant temperature Low
	X	Starting battery Under/Over Voltage

Manual Run

Immediately begins the crank cycle to start engine and produce power (MAN mode only).

Start

Start generator set operation (MAN mode only).

Stop

Stops the Engine and generator set (MAN mode only).

Display

Displays setpoints, adjustments, Alarms and Warning conditions and Operating Mode selections.

Page

Changes menu displayed – Measurement, Adjustment or History.

Mode ◀ and ▶

Allows selection of OFF – MAN – AUTO mode choices.

Horn Reset

Deactivates the Horn output.

Fault Reset

Reset Alarms and Warnings.

▲ and ▼

Selects the menu choice, select the setpoint or select the menu or increase/decrease the setpoint value.

Enter

Confirm and accept changed setpoint value.

Enter + ▲ and ▼ Adjusts display contrast.

Enter+ Fault Reset Clears engine ECU faults.

Table 4-4 Manual Mode Sequence Description

Menu	Status	Condition of Transition	Action ¹	Next State
Main Measurement	Ready	Start request	PRESTART on, Prestart time counter started	PRESTART
		RPM > 2 or Oil pressure detected or Gen voltage > 10V		Stop (Stop fail)
		OFF mode selected or Shut down alarm active		Not Ready
	Not Ready	RPM < 2, Oil pressure not detected, Vgen < 10V, no shutdown alarm active, other than OFF mode selected		Ready
	Prestart	Prestart time elapsed	STARTER on, FUEL SOLENOID on, MaxCrank time counter started	Cranking
	Cranking	RPM > Start RPM	STARTER off, PRESTART off	Starting
		D+ input activated or oil pressure detected or Gen voltage > 25% Vgnom	STARTER off, PRESTART off	Cranking
		MaxCrank time elapsed, 1st attempt	STARTER off, FUEL SOLENOID off, STOP SOLENOID on, CrankFail pause timer started	Crank pause
		MaxCrank time elapsed, last attempt	STARTER off, PRESTART off	Shutdown (Start fail)
	Crank Pause	CrankFail pause elapsed	STARTER on, FUEL SOLENOID on, STOP SOLENOID off, MaxCrank time counter started	Cranking
	Starting	30% Nominal speed reached	READY TO LOAD on, MaxStabTime counter started	Running
	Running	Stop request	READY TO LOAD off, Cooling time timer started	Cooling
		RPM = 0 or any other shutdown condition	READY TO LOAD off, FUEL SOLENOID off	Shutdown
	Loaded	RPM = 0 or any other shutdown condition	FUEL SOLENOID off, STOP SOLENOID on, READY TO LOAD off	Shutdown
	Cooling	Cooling time elapsed	FUEL SOLENOID off, STOP SOLENOID on	Stop
		RPM = 0 or any other shutdown condition	FUEL SOLENOID off, STOP SOLENOID on	Shutdown
		Start request	READY TO LOAD on	Running
	Stop	RPM = 0, Oil pressure not detected, Vgen < 10V		Ready
		60 sec. Elapsed		Stop (Stop fail)

¹ Some output conditions are optional and may require additional programming of field connection. See appropriate wiring diagram.

Adjustment Menu

The adjustment menu, Figure 4-8 allows setting engine and generator values such as Passwords, Pre-Start Time, Crank Time, Cool Down Time, Alarm Conditions and values, Shutdown Conditions and values, power transfer settings, etc.

Figure 4-8 Adjustment Menu

```

> ENGINE BASIC
ENGINE PROT
GEN BASIC
GEN PROTECT
    
```

Use ▲ and ▼ to move the cursor to the desired parameter.
 Press ENTER to select the parameter group.
 Press PAGE to move to the next page of menu items.

Alarm List

Shows the active alarms and warnings. Press fault reset to clear the list.

ECU Alarm List

Shows the active ECU (engine control unit) fault codes. Press ENTER + fault reset to clear the list.

Alarms

Following alarms are available:

Sensor fail (FLS) see Table 4-5

Sensor fail is detected when measured value is 6% out of selected sensor characteristic.
Sensor fail is indicated by ##### symbol instead measured value.

Warning (WRN) see Table 4-5

When warning comes up, only alarm outputs and common warning output are closed.

Shut down (SD) see Table 4-5

When the shut-down alarm comes up, IntelliLite opens outputs GCB CLOSE/OPEN, FUEL SOLENOID, STARTER and PRESTART to stop the engine immediately. Alarm outputs and common shutdown output are closed. Active or not reset protection disables start.

Table 4-5 Possible Warnings

Events specification	Protection type
Wrn Oil press	WRN
Sd Oil press	SD
Wrn Water temp	WRN
Sd Water temp	SD
Wrn Wtemp Low	WRN
Wrn Fuel Level	WRN
Sd Fuel Level	SD
Battery voltage <, >	WRN
Battery flat	SD
Start fail	SD
Vgen <, >	SD
Vgen unbl	SD
Fgen <, >	SD
Igen unbl	SD
Overload	SD
RPM over	SD
RPM under	SD
PickupFault	SD
Stop fail	SD
WrnServiceTime	WRN
Emergency Stop	SD
ECU Common Warning	WRN
ECU Shutdown	SD

Inputs and Outputs

Any Binary input or output can be configured to any controller terminal Inputs are BI1 – BI7, Outputs are BO1 – BO7) or changed to different function by LiteEdit software. There is fixed 1 sec delay when any binary input is configured as protection.

Table 4-6 Binary Inputs

Alarm	Alarm type Warning or Shut down Alarm active All the time, or Engine running only
Rem start/stop	External request for engine run. AUT mode only.
Emergency stop	If the input is opened, shut down is immediately activated. Input is inverted (normally closed).
Rem start/stop	External request for engine run. AUT mode only.

Table 4-7 Binary outputs

Starter (relay output)	The closed relay energizes the starter motor. The relay opens if: <ul style="list-style-type: none">• The firing speed is reached or• Maximum time of cranking is exceeded or• Request to stop occurs
Fuel solenoid (relay output)	Closed output opens the fuel solenoid and enables the engine start. The output opens if: Emergency stop occurs or Cooled gen-set is stopped or In pause between repeated starts
ECU PWR Relay	The output closes at the beginning of Prestart and OPENS if the engine is stopped.
Prestart	Output is closed prior to the engine start (Prestart) and opens when START RPM speed is reached. During repeated crank attempts the output is closed too. The output could be used for pre-glow, pre-heat or prelubrication.
Common Sd	Output closes when any shut-down alarm appears. The output opens, if alarm is not active and FAULT RESET is pressed. Used for shunt trip.

Analog Inputs

Three analog inputs for resistive sensor 0 to 2400 ohms measuring are available on IL controller. Use LiteEdit software to modify configuration.

The Analog inputs values assignment (AI1 = Oil press, AI2 = Water temp, AI3 = Fuel level) is fixed. It is possible to configure on each Analog input:

- Reading from IL Analog inputs or from Engine Control Unit via CAN bus (J1939)
- Sensor characteristics – from the list,
- Value dimension (e.g. psi – bars, °F – °C, % – l)
- Number of decimal points (0, 1, 2, ...).

Note: Corresponding Analog input terminal is dead when reading is switched to ECU.

All values from ECU shall show ####, but no alarm is displayed when CAN communication is interrupted.

Warning and shut-down limits are adjusted in Engine protection group.

Table 4-8 Analog Inputs

AI1 Oil press	Oil pressure analog input. Default VDO sensor in range 0 to 145 psi.
AI2 Water temp	Water temperature analog input. Default VDO sensor in range 32 to 212°F
AI3 Fuel level	Fuel level analog input. Default VDO sensor 0–180R = 0–100%.

Set points

Table 4-9 Basic Setpoints

EnterPassword	Password is a four-digit number. Password enables change of relevant protected set points Use ↑ or ↓ keys to set and ENTER key to enter the password.
ChangePassword	Use ↑ or ↓ keys to set and ENTER key to change the password.
Gen-set name	User defined name, used for IntelliLite identification at remote phone or mobile connection. Gen-set name is max 14 characters long and have to be entered using LiteEdit software.
Nomin power(3ph)	Nominal power of the generator in three phases connection. Step: 1 kW; Range: 1 – 3000 kW
Nomin power(1ph)	Nominal power of the generator in single-phase connection. Step: 1 kW; Range: 1 – 3000 kW
CT Ratio	Gen-set phases current transformers ratio. Step: 1 A; Range: 1 – 5000 A / 5A
PT ratio	Gen-set potential transformers ratio. Step: 0,1 V / V; Range: 0,1 – 500,0 V / V
Nominal freq	Nominal generator frequency (usually 50 or 60 Hz) Step: 1Hz; Range: 45 – 65 Hz
Gear teeth	Number of teeth on the engine gear for the pick-up. Set to zero, if no pick-up is used. Engine speed is counted from the generator frequency. Step: 1; Range: 0 – 500 Note: Generator frequency can be used only when generator voltage (min 5V) is present before reaching of the firing speed (Starting RPM) after start.
Nominal RPM	Nominal engine speed. Step: 1RPM; Range: 100 – 4000 RPM.
FLTRESGOTOMAN	DISABLED: Controller stays in AUT mode after Fault reset. ENABLED: Automatic switch from AUT (or TEST) to MAN mode after Fault reset to avoid automatic engine start. This function is active for Shut down protection only.
DispBackLightTO	Timeout after which the display backlight is switched off. Step: 1 min Range: 0 – 60 min Default value: 0 = the display lights all the time
Mode IL [OFF, MAN, AUT]	Equivalent to Controller mode changes by MODE▶ or MODE◀ buttons. Note: Controller Mode change can be separately password protected.
RS232 mode [Standard/Modbus]	Communication protocol switch. Standard: LiteEdit communication protocol. Modbus: Modbus protocol. Note: For detail description see chapter Modbus protocol.
Num rings AA	Number of rings prior to open modem connection. Step: 1; Range: 1 – 30 Note: NumberRings AA change is not activated immediately. It is activated after controller is switched on or when modem is connected to controller.

Table 4-10 Engine Setpoints

Start RPM	"Firing" speed when iL controller stops cranking (starter goes OFF). Step: 1% of nominal RPM; Range: 5 – 50 %
Starting POil	When reached controller stops cranking (starter goes OFF). Step: 0,1 psi; Range: –100 – 10000 Note: There are three conditions for stop cranking: Starting RPM, StartingPOil and D+ (when enabled). Starter goes off when any of these conditions is valid.
Prestart time	Time of closing of the PRE–START output prior to the engine start. Set to zero if you want to leave the output PRE–START open. Step: 1s; Range: 0 – 600 s
MaxCrank time	Maximum time limit of cranking. Step: 1s; Range: 1 – 60 s
CrnkFail pause	Pause between crank attempts. Step: 1s; Range: 5 – 60 s
Crank attempts	Max number of crank attempts. Step: 1; Range: 1 – 10
Idle time	Idle time delay starts when RPM exceeds Start RPM . Start fail is detected when during Idle state RPM decreases below 2. During the Idle time timer running the binary output IDLE/NOMINAL is opened, when it elapses the IDLE/NOMINAL output closes. Binary output IDLE/NOMINAL opens during Cooling period again. Step: 1 s; Range: 0 – 600 s Note: If the IDLE function not supported on the governor, set the Idle time nevertheless to minimum 5s to avoid Underspeed possibly caused by instability of the engine short after start.
GCB CloseDelay	GCB can be closed earliest GCB CloseDelay after Stabil time when all electric values are in overunder voltage and over–under frequency limits. Step: 1 s; Range: 0 – 300 s
Stabil time	Generator Nominal voltage is detected during genset start after starter is switched off and Idle time elapses. Electric generator protections are active since detection. Step: 1 s; Range: 0 – 300 s
MinStpValvTime	Binary output Stop solenoid closes when stop sequence begins and closes at least for MinStpValvTime. Example MinStpValvTime = 20 sec. a) When engine stops (RPM=0) in 10 seconds, Binary output Stop solenoid still stays closed for 10 sec. b) When engine stops in 30 seconds, Binary output Stop solenoid opens 10 seconds after RPM=0 and Vg =0 and Oil pressure = 0. Those 10 sec is fix time for safe stop. Step: 1s; Range: 0 – 180 s Note: Stop of engine is detected when all following conditions are met: RPM =0, Oil pressure < StartingPOil and Generator voltage < 10 VAC. Stop fail is detected when is difference between those conditions, e.g RPM=O and Generator voltage > 10V.

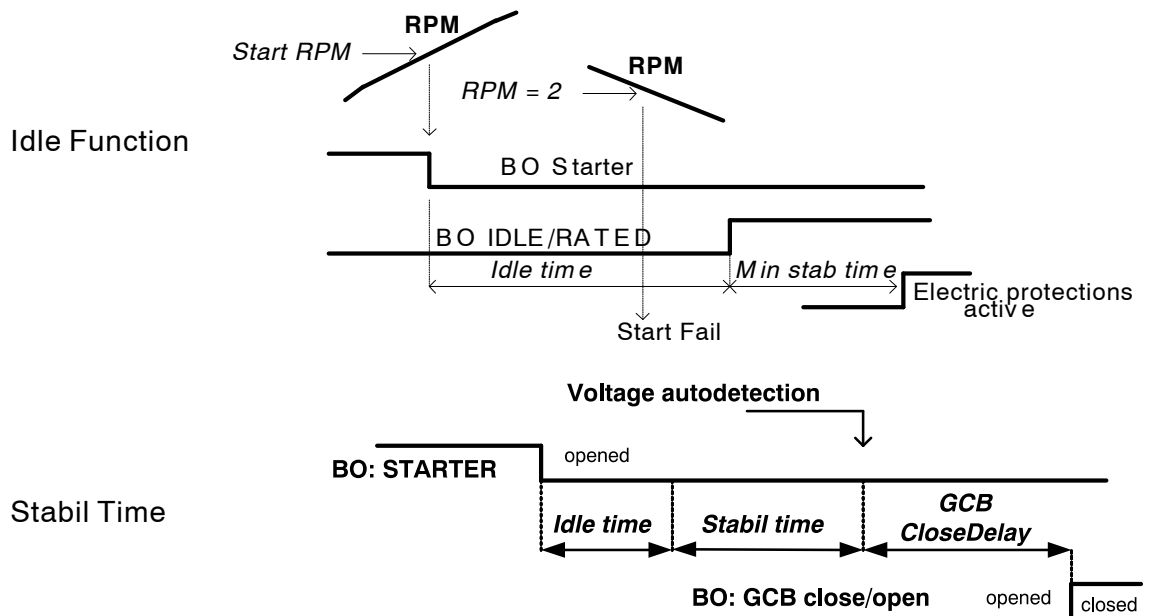

Table 4-10 Engine Setpoints Continued

Cooling time	Runtime of the unloaded gen-set to cool the engine before stop. Step: 1s; Range: 0 – 3600 s
AfterCoolTime	Runtime of engine after cooling pump. Binary output Cooling pump is closed when the engine starts and opens AfterCool time delayed after gen-set stops. Step: 1s Range: 0 – 3600s
CoolingSpeed	Selects the function of the Binary output IDLE/NOMINAL during engine Cooling state. NOMINAL : Cooling is executed at Nominal speed and generator protections are active. IDLE: Cooling is executed at Idle speed and generator protections are switched off. Hint: Binary output IDLE/NOMINAL must be configured and connected to speed governor. Engine Idle speed must be adjusted on speed governor.
D+ function	ENABLED: The D+ terminal is used for both functions “running engine” detection and charge fail detection. CHRGFAIL: The D+ terminal is used for charge fail detection only DISABLED: The D+ terminal is not used. Note: Magnetization current is independent of this setpoint value.

Table 4-11 Engine Protect Setpoints

ECUFreqSelect	This setpoint should be used only for Volvo and Scania engines.
ECU Speed Adjust	This setpoint should be used only for Volvo and Scania engines.
WTBF Accept RPM	The WtBfAcceptRPM delay setpoint will start to count down since cranking. Controller waits before communicating with the ECU for this time. This is because the JD engine passes some erroneous RPM signals during the first 500ms. Step: 0,1s Range: 0 – 3s
Eng prot del	During the start of the gen-set, some engine protections have to be blocked (e.g. Oil pressure). The protections are unblocked after the Protection del time. The time starts after reaching Start RPM. Step: 1s; Range: 0 – 300 s
Horn timeout	Max time limit of horn sounding. Set to zero if you want to leave the output HORN open. Step: 1s; Range: 0 – 600 s
Overspeed	Threshold for over speed protection. Step: 1% of nominal RPM; Range: 100 – 150%
Wrn Oil press	Warning threshold level for ANALOG INPUT 1. Step: 1 psi; Range: Sd Oil press – 10000
Sd Oil press	Shutdown threshold level for ANALOG INPUT 1. Step: 1 psi; Range: –100 – Wrn Oil press
Oil press del	Delay for ANALOG INPUT 1. Step: 1 s; Range: 0 – 180
Sd Water temp	Warning threshold level for ANALOG INPUT 2. Step: 1 °C; Range: Wrn Wtemp – 10000
Wrn Water temp	Warning threshold level for ANALOG INPUT 2. Step: 1 °F; Range: Wrn Wtemp low – Sd Water temp
Wrn Wtemp low	Warning threshold level for low value on ANALOG INPUT 2. Step: 1 °F; Range: –100 – Wrn Water temp
Water temp Low del	Delay for ANALOG INPUT 2 Wrn Wtemp low. Step: 1 s; Range: 1–180 s
Water temp del	Delay for ANALOG INPUT 2 alarm. Step: 1 s; Range: 0 – 180 s
Wrn Fuel Level	Warning threshold level for ANALOG INPUT 3. Step: 1 %; Range: Sd Fuel Level – 10000
Sd Fuel Level	Shutdown threshold level for ANALOG INPUT 3. Step: 1 %; Range: –100 – Wrn Fuel Level
Fuel Level del	Delay for ANALOG INPUT 3. Step: 1 s; Range: 0 – 180 s
Batt overvolt	Warning threshold for high battery voltage. Step: 0,1 V; Range: Batt undervolt – 40V
Batt undervolt	Warning threshold for low battery voltage. Step: 0,1 V; Range: 8V – Batt overvolt
Batt volt del	Delay for low battery voltage alarm. Step: 1s; Range: 0 – 600 s
NextServTime	Counts down when engine running. If reaches zero, an alarm appears. Step: 1h; Range: 0 –65535h

Table 4-12 Generator Protect Setpoints

Overload	Threshold for generator overload (in % of Nominal power) Step: 1% of Nominal power; Range: 0 – 200%
Overload Wrn	Threshold for generator overload warning (in % of Nominal power) Step: 1% of Nominal power; Range: 0 – 200%
Overload del	Delay for generator overload alarm. Step: 0.1s; Range: 0 – 60.0 s
Ishort	Shutdown occurs when short circuit limit Ishort limit is reached. Step: 1 % of Nominal current; Range: 100 – 500 %
2lnom del	IDMT curve shape selection. 2lnom del is Reaction time of IDMT protection for 200% overcurrent Igen = 2* Nominal current. Step: 0,1 s; Range: 0,1 – 20 s IDMT is “very inverse” generator over current protection. Reaction time is not constant but depends on generator over current level according following formula. Reaction time is limited up to 900 sec = 15 minutes. IDMT protection is not active for Reaction time values longer than 15 minutes. $\text{Reaction Time} = \frac{2\text{lnom del} * \text{Nomin current}}{\text{Igen} - \text{Nomin current}}$
Curr unbal	Threshold for generator current asymmetry (unbalance). Step: 1% of Nominal current; Range: 1 – 100% of Nominal current
Curr unbal del	Delay for generator current assymetry. Step: 0.1 s; Range: 0 – 60.0 s
Gen >V	Shutdown level for generator overvoltage. All three phases are checked. Maximum out of three is used. Step: 1% of Nominal voltage; Range: Gen >V Wrn –200%
Gen >V Wrn	Warning level for generator overvoltage. All three phases are checked. Maximum out of three is used. Step: 1% of Nominal voltage; Range: Gen <V Wrn – Gen >V
Gen <V Wrn	Warning level for generator under voltage. All three phases are checked. Minimum out of three is used. Step: 1% of Nominal voltage; Range: Gen <V – Gen >V Wrn
Gen <V	Shutdown level for generator under voltage. All three phases are checked. Minimum out of three is used. Step: 1% of Nominal voltage; Range: 0% – Gen <V Wrn
Gen V del	Delay for generator under voltage and over voltage alarm Step: 0.1s; Range: 0 – 60 s
Volt unbal	Threshold for generator voltage unbalance alarm. Step: 1% of Nominal voltage; Range: 0 – 100% of Nominal voltage
Volt unbal del	Delay for generator voltage unbalance alarm. Step: 0.1s; Range: 0 – 60.0 s
Gen >f	Shutdown level for generator over frequency. Step: 0.1% of Nominal frequency; Range: Gen > Wrn – 200.0%
Gen >f Wrn	Warning level for generator over frequency. Step: 0.1% of Nominal frequency; Range: Gen <f Wrn – Gen >V
Gen <f	Shutdown level for generator under frequency. Step: 0.1% of Nominal frequency; Range: 0.0 – Gen <f Wrn
Gen <f Wrn	Warning level for generator under frequency. Step: 0.1% of Nominal frequency; Range: Gen <f – Gen >f Wrn
Gen f del	Delay for generator under frequency and over frequency alarm. Step: 0.1s; Range: 0 – 60.0 s

Table 4-13 Sensor Spec Setpoints

Calibr AI1,AI2, AI3	Calibrating constant to adjust the measured value of IL analog inputs. Physical dimension of calibrating constant is corresponding to Analog input. Step: 1; Range: -1000 to +1000
AnOut-kW/20mA	Conversion coefficient from gen-set power to iG-IOM or PTM analog output. Step: 1; Range: 1 to 32000

Table 4-14 IOM/PTM Module Setpoints

AnIInIOM1 lev1	The level for IOM ANALOG INPUT 1 alarm detection. Step: 1; Range: -100 to +10000
AnIInIOM1 lev2	The level for IOM ANALOG INPUT 1 alarm detection. Step: 1; Range: -100 to +10000
AnIInIOM1 del	Delay for IOM ANALOG INPUT 1 alarm. Step: 1 s; Range: 0 - 180 s
AnIInIOM2 lev1	The level for IOM ANALOG INPUT 2 alarm detection. Step: 1; Range: -100 to +10000
AnIInIOM2 lev2	The level for IOM ANALOG INPUT 2 alarm detection. Step: 1; Range: -100 to +10000
AnIInIOM2 del	Delay for IOM ANALOG INPUT 2 alarm. Step: 1 s; Range: 0 - 180 s
AnIInIOM3 lev1	The level for IOM ANALOG INPUT 3 alarm detection. Step: 1; Range: -100 to +10000
AnIInIOM3 lev2	The level for IOM ANALOG INPUT 3 alarm detection. Step: 1; Range: -100 to +10000
AnIInIOM3 del	Delay for IOM ANALOG INPUT 3 alarm. Step: 1 s; Range: 0 - 180 s
AnIInIOM4 lev1	The level for IOM ANALOG INPUT 4 alarm detection. Step: 1; Range: -100 to +10000
AnIInIOM4 lev2	The level for IOM ANALOG INPUT 4 alarm detection. Step: 1; Range: -100 to +10000
AnIInIOM4 del	Delay for IOM ANALOG INPUT 4 alarm. Step: 1 s; Range: 0 - 180 s The protection of IOM/PTM inputs is activated by over crossing the limits.
Calibr AIiIOM 1..4	Calibrating constant to adjust the measured value of IOM/PTM analog inputs. Physical dimension of calibrating constant is corresponding to Analog input. Step: 1; Range: -1000 to +1000

Digital Engine Controller Description EM0046A45 (MRS19) Continued

Figure 4-9 Controller Connection Diagram

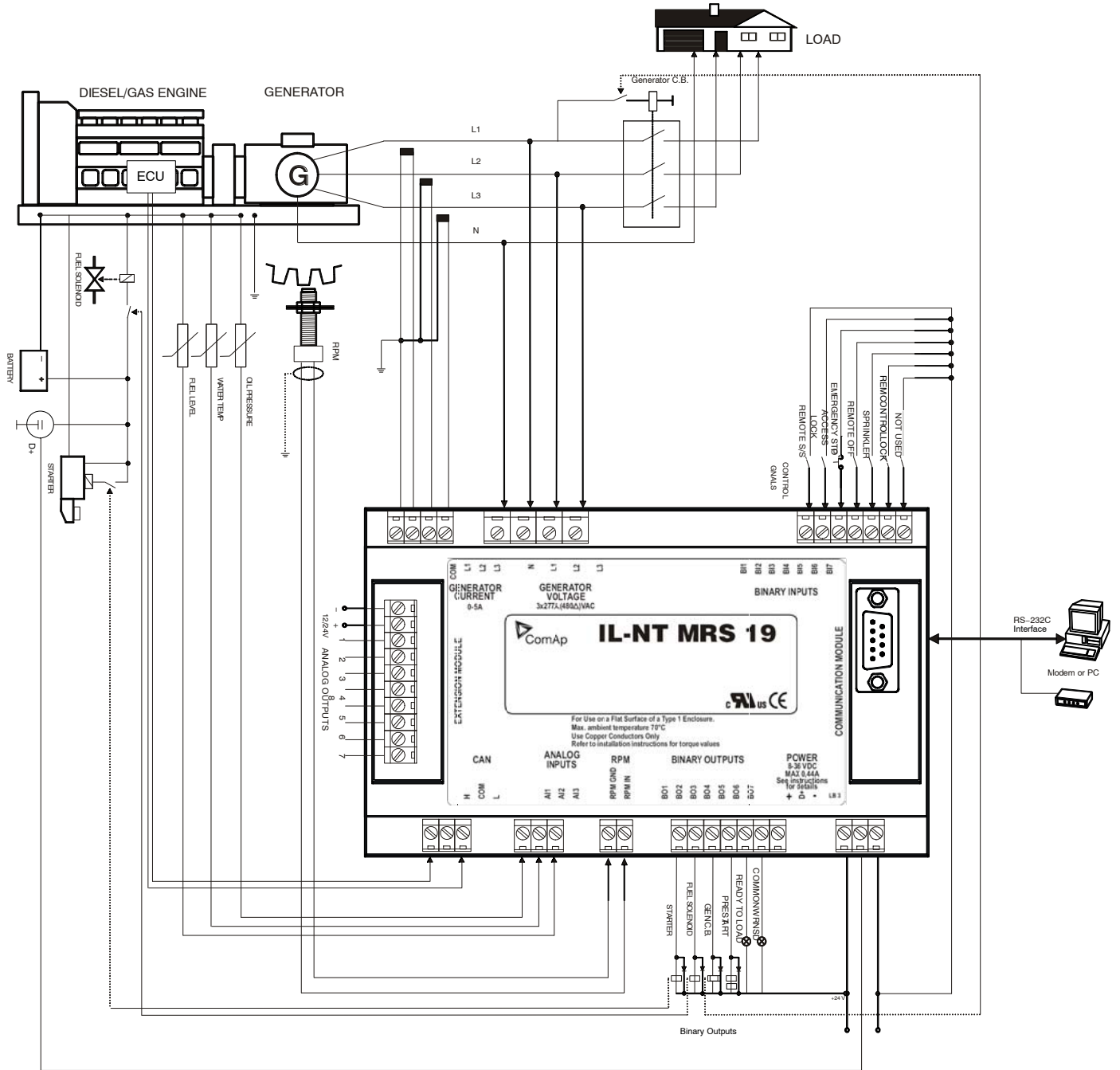
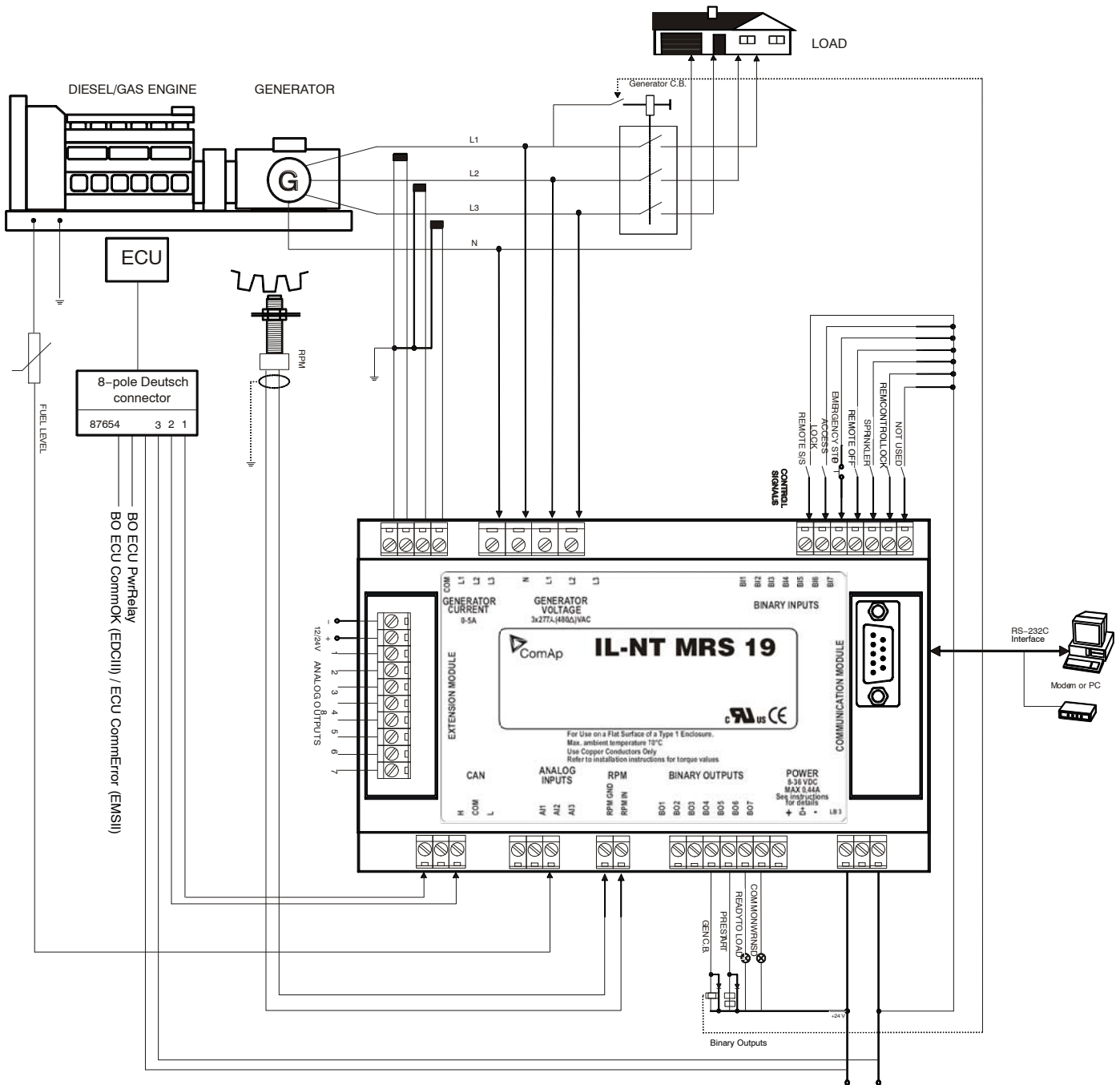

Figure 4-10 Controller Connection Diagram



Section 5

Troubleshooting and Maintenance

WARNING: Never “jump start” a generator to start the engine. If the battery charge is insufficient to start the engine, charge or replace the battery and try to restart. Jump starting a battery can cause the battery to explode and cause severe injury or death to anyone in the area.

Caution: If a dead battery is suspected charge battery (or replace), and then attempting starting. Damage to engine control may result from jump starting.

Maintenance

This manual contains only very minimal engine maintenance instructions. Refer to the engine manufacturer’s owner’s manual for specific engine maintenance instructions for your generator set. Any maintenance instructions or recommendations in the engine owner’s manual take precedence over any of the following general recommendations.

General:

1. Inspect the fuel system for leaks. Replace all defective components immediately.
2. Inspect and replace any fuel line that shows signs of deterioration.
3. Inspect all the fuel clamps to ensure they are tight.
4. Make sure the fuel cap fits snugly on the fuel tank and that the fuel tank contains no leaks.
5. Inspect and clean the battery posts and the associated battery cable terminals.
6. Inspect the external wire cables and connectors used with the generator set for cuts, fraying, or loose connections. Repair or replace any problems prior to using the unit.

Engine:

1. Clean and/or replace any fuel, oil, and/or air filters per the engine manufacturers’ guidelines.
2. Check oil level regularly; at least every 5 to 8 operating hours. Maintain the proper oil level.
3. Change the oil as is recommended in the engine manufacturer’s owner’s manual.
4. Clean the cooling fins on the engine to keep the engine’s heat dissipation potential at it’s maximum.
5. Inspect and clean all governor and fuel supply linkages so they operate properly.

Alternator: (also called Generator End)

This generator set must be run at its proper speed to obtain the correct electrical power at its output. All engines have a tendency to slow down when a load is applied to it. The engine governor is designed to hold the operating speed as nearly constant as possible. When the electrical load is increased, the engine is more heavily loaded and engine speed drops slightly. This slight decrease in engine speed results in a slight decrease in generator voltage and frequency output. This voltage and frequency variation has no appreciable effect in the operation of motors, lights, and most appliances and tools. However, timing devices and clocks may not keep perfect time.

1. Clean the generator set and remove any and all dust, dirt, or other foreign material.
2. Inspect and clean the cooling air intake and exhaust louvers of the generator end. Make sure they are clean. Remove dirt or any buildup that may restrict the cooling air flow.
3. Clean the generator set and its components with a damp cloth or sponge. Never use a water hose or pressure washer as this may damage electrical components.
4. Inspect and replace any control panel components that are broken or not working properly (receptacles, circuit breakers, switches, etc.)

Problems and Solutions

Some of the more common problems are listed in Table 5-1. This information is intended to be a check or verification that simple causes can be located and fixed. It is not an exhaustive “how to” for all types of problems. Procedures that require in depth knowledge or skills (like flashing the field) should be referred to an authorized service department.

Table 5-1 Troubleshooting Guide

Problem	Possible Cause	Remedy
Engine will not start	No fuel. Restricted air flow. Damaged glow plug	Check that fuel valves are ON. Check fuel level in fuel tank. Check/replace air filter. Check/replace glow plug(s). Check that engine switch is in Start position.
Engine will not crank	Dead battery.	Remove battery and trickle charge or replace with new battery. Never Jump Start.
Engine starts but will not run smoothly	Fuel or ignition problem	Refer to engine manual.
Engine overheats	Excessive load Debris or dirt buildup on engine Low Coolant Level	Remove one or more electrical loads. Remove debris. Clean engine surfaces to allow cooling. Replenish coolant
Output voltage varies	Irregular speed Fluctuating speed Loose terminal or load connections Defective alternator bearing (uneven air gap)	Check engine for malfunction or load for fluctuation Stabilize load. The addition of a lamp load (resistance load) may compensate partially for load changes caused by intermittent motor operation. Do not overload. Verify all connections are proper and check tightness torque of terminals. Replace worn bearing
Low Voltage (0–15 VAC output)	Bad Voltmeter Bad/Open Circuit Breaker/Fuse Bad Connection Loss of Residual Magnetism Bad Voltage Selector Switch Bad Stator Windings	Measure the voltage across the voltage meter with an accurate voltmeter to verify. Check continuity across Breaker/Fuse. Replace if defective. Check wiring including grounds, crimps and connection points. Repair defects. The generator needs to be flashed. Contact service center to perform this procedure. Replace switch, contact service center to perform this procedure. Contact service center to perform this procedure.
Low Voltage (15–20 VAC output)	Bad Voltmeter Incorrect Engine Speed Bad/Open Circuit Breaker/Fuse Bad Connection Bad Voltage Selector Switch Bad Stator Windings Bad Voltage Adj. Rheostat Bad Voltage Regulator Bad Rotor Diodes Bad Rotor Windings	Measure the voltage across the voltage meter with an accurate voltmeter to verify. Remove electrical load, output should be 61–62 Hertz adjust engine speed if necessary. Check continuity across Breaker/Fuse. Replace if defective. Check wiring including grounds, crimps and connection points. Repair defects. Replace switch, contact service center to perform this procedure. Contact service center to perform this procedure. Replace rheostat, contact service center to perform this procedure. Replace regulator, contact service center to perform this procedure. Contact service center to perform this procedure. Contact service center to perform this procedure.
Incorrect voltage output	Bad Voltmeter Incorrect Engine Speed Bad Voltage Adj. Rheostat Bad Voltage Regulator Bad Connection Bad Voltage Selector Switch	Measure the voltage across the voltage meter with an accurate voltmeter to verify. Remove electrical load, output should be 61–62 Hertz adjust engine speed if necessary. Replace rheostat, contact service center to perform this procedure. Replace regulator, contact service center to perform this procedure. Check wiring including grounds, crimps and connection points. Repair defects. Replace switch, contact service center to perform this procedure.
High output voltage	Excessive speed	Check engine for malfunction

Table 5-1 Troubleshooting Guide Continued

Problem	Possible Cause	Remedy
Genset will not pull load	Incorrect Engine Speed	Remove electrical load, output should be 61–62 Hertz adjust engine speed if necessary.
	Load not connected properly	Verify voltage at the load and the connections to the proper receptacle or load terminal block.
	Load too large for unit	Verify load amperage is less than the generator set rated. Note: For inductive loads, use the starting amperage rating of the load (not the running amperage rating). Starting amps may be as much as 5 times the running amps.
Electrical shock when frame is touched	Static charge. Grounded armature or field coil.	Ground generator frame at local reference ground (see Section 3). Contact service center.
Mechanical noise (alternator)	Defective bearing	Replace bearing.
	Rotor rubbing on stator	Bad bearing – replace. Bent shaft – contact service center. Loose end bell – tighten; Loose drive Discs – tighten
	Loose or misaligned coupling	Tighten; align coupling and alternator shaft to engine shaft.
Trailer lights inoperable	Trailer to tow vehicle connection	Connect trailer lighting connector to tow vehicle trailering connector
	Trailer electrical connection not compatible	Use adapter plug to convert from connector style found on trailer to connector style found on tow vehicle or replace connector with compatible mate
	Insufficient Ground connection	Verify there is a ground wire connection from the tow vehicle to the trailer. Do not rely on the trailer tow coupling for the battery ground connection. Repair as necessary.
	Faulty light bulb	Replace as necessary
Trailer sways during towing	Tow vehicle trailering ratings too small	Check tow vehicle ratings meet or exceed the Gross Vehicle Weight Rating (GVWR) of the trailer. Use larger tow vehicle as necessary. Seek expert advise.
	Trailer tongue not level on tow vehicle	Adjust trailer or tow vehicle as necessary for trailer tongue to be level or slightly higher than rear of tow vehicle when additional supports have been removed. View and make adjustments while vehicle and trailer are on level surface. Seek expert advise.
	Towing at excessive speed	Reduce tow vehicle speed and use caution while braking. Obey all local laws and regulations, never exceed the posted speed limit, and use reasonable care when towing any type of trailer. Contact local authority having jurisdiction.

Note: After the engine is stopped, there is a 15 second restart delay before engine cranking.

Fault Shutdowns Under certain operating conditions, onboard sensors determine that a condition may cause damage if operation continues. The onboard controller is programmed to sound an alarm or immediately stop (shutdown) the generator. These conditions are as follows:

1. An alarm fault is indicated by an alarm light located on the operator panel:
 - a. Overspeed – indicates the engine governor allowed speed to exceed safe limits.
 - b. Overcrank – indicates engine failed to start within programmed time period.
 - c. Low Oil Pressure – Safe engine operating oil pressure was not maintained.
 - d. Overtemperature – indicates safe operating coolant temperature was exceeded.
2. Engine cannot be restarted until the alarm condition is corrected.
3. Reset the alarm condition (after alarm condition is corrected) by pressing “Reset”.
Operation can be attempted, observe the operator panel when operation is resumed to ensure alarm condition is removed.

Overload When maximum current output exceeds the output breaker limit, the main breaker will trip. When this occurs, the load must be reduced and the breaker reset before operation can be resumed.

Note: The Main Breaker cannot be reset if load connection box door is open. This door must be closed before the breaker can be reset to connect the electrical load.

Service & Parts Service and parts for your generator can be obtained from an authorized service center. Please have the following information available prior to contacting the service center:

The model number and serial number of the generator set.

A complete and accurate description of the part (part number if known).

Note: Engine parts can usually be obtained from a local distributor by using the information in the engine manufacturer’s owner’s manual.

Appendix A Wiring Diagrams

Replacement Parts Engine parts are identified in the engine manual that was provided with your generator set.

IMPORTANT: Fuses are installed in the control box to protect the engine controller and associated control circuits. When replacing fuses, use the exact replacement fuse (manufacturer and part number).

Wiring Diagrams Wiring diagrams for these generators are contained on the following pages of this appendix.

Figure A-2 TS25 Diagram

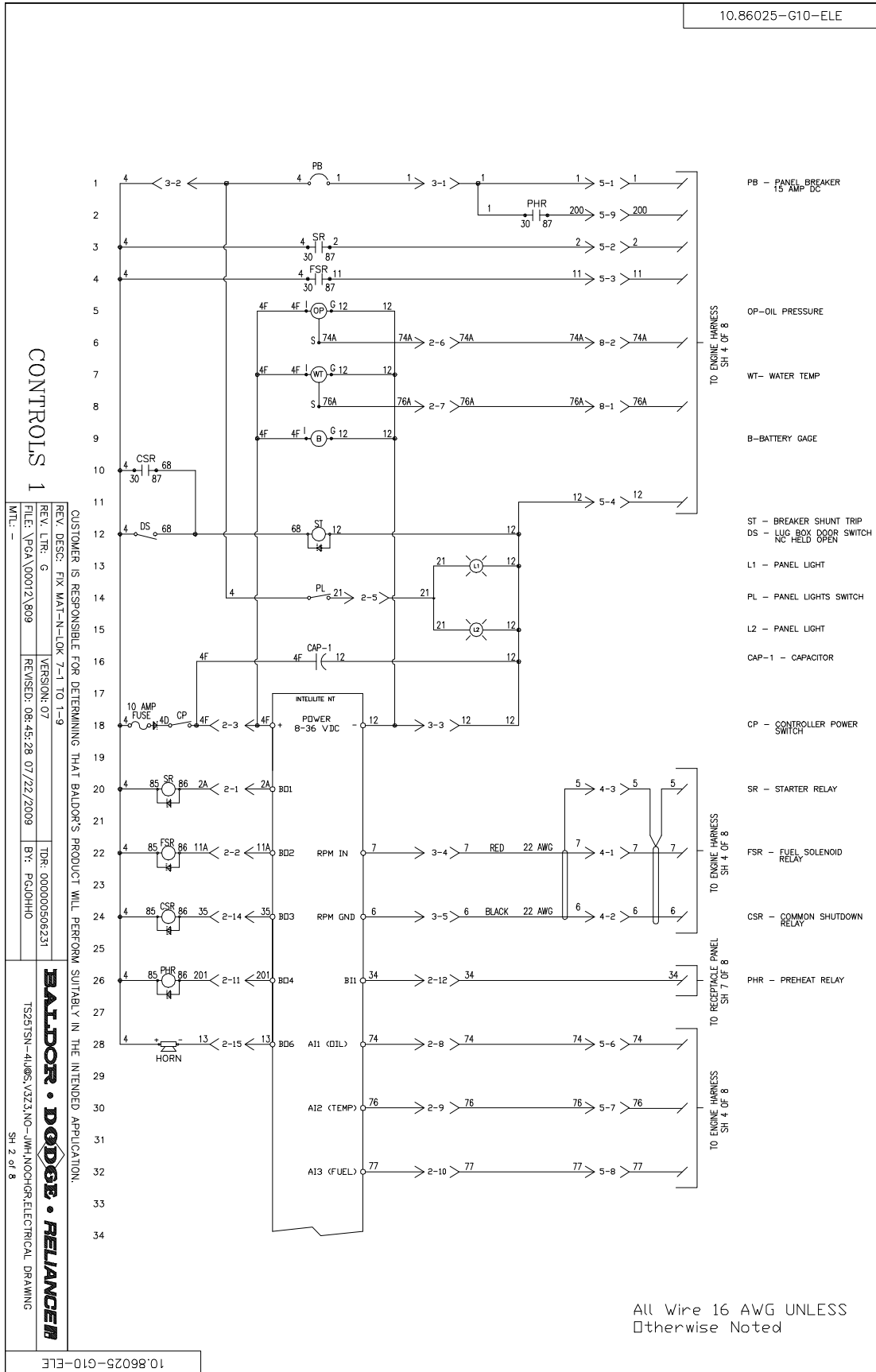
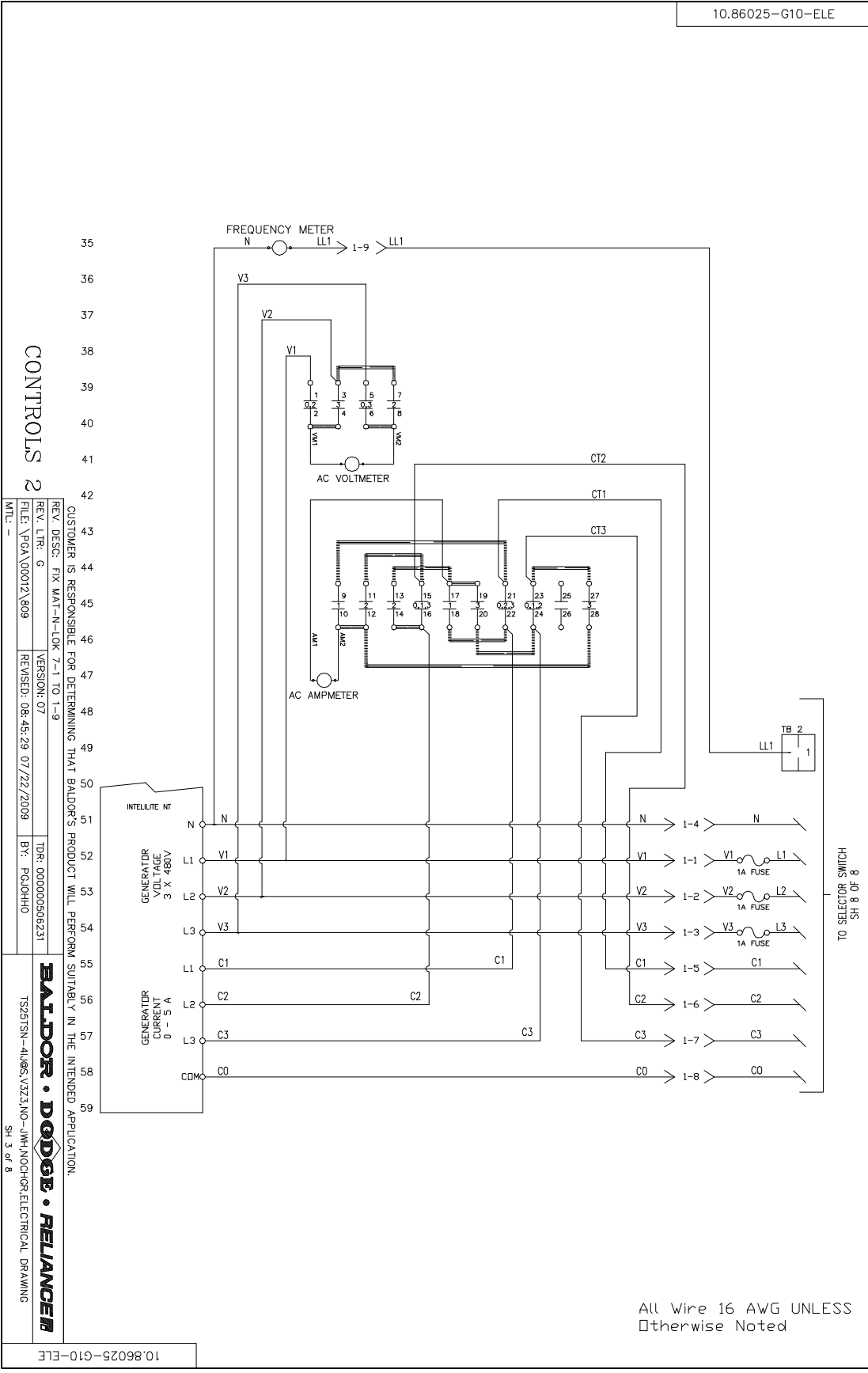

Figure A-3 TS25 Diagram

10.86025-G10-ELE



CONTROLS 2

REV. LTR: G
 FILE: \PGA\00012\809
 MTL: -
 CUSTOMER IS RESPONSIBLE FOR DETERMINING THAT BALDOR'S PRODUCT WILL PERFORM SUITABLY IN THE INTENDED APPLICATION.
 REV. DESG: FIX MAT-N-LOK 7-1 TO 1-9
 VERSION: 07
 REVISED: 08-45:29 07/22/2009
 TOR: 000000506231
 BY: PCJOHHD

BALDOR • DODGE • RELIANCE
 TS25TSN-4I08S,V3Z3,NO-JMH,NOCH6R-ELECTRICAL DRAWING
 SH 3 of 8

10.86025-G10-ELE

All Wire 16 AWG UNLESS
 Otherwise Noted

Figure A-5 TS25 Diagram

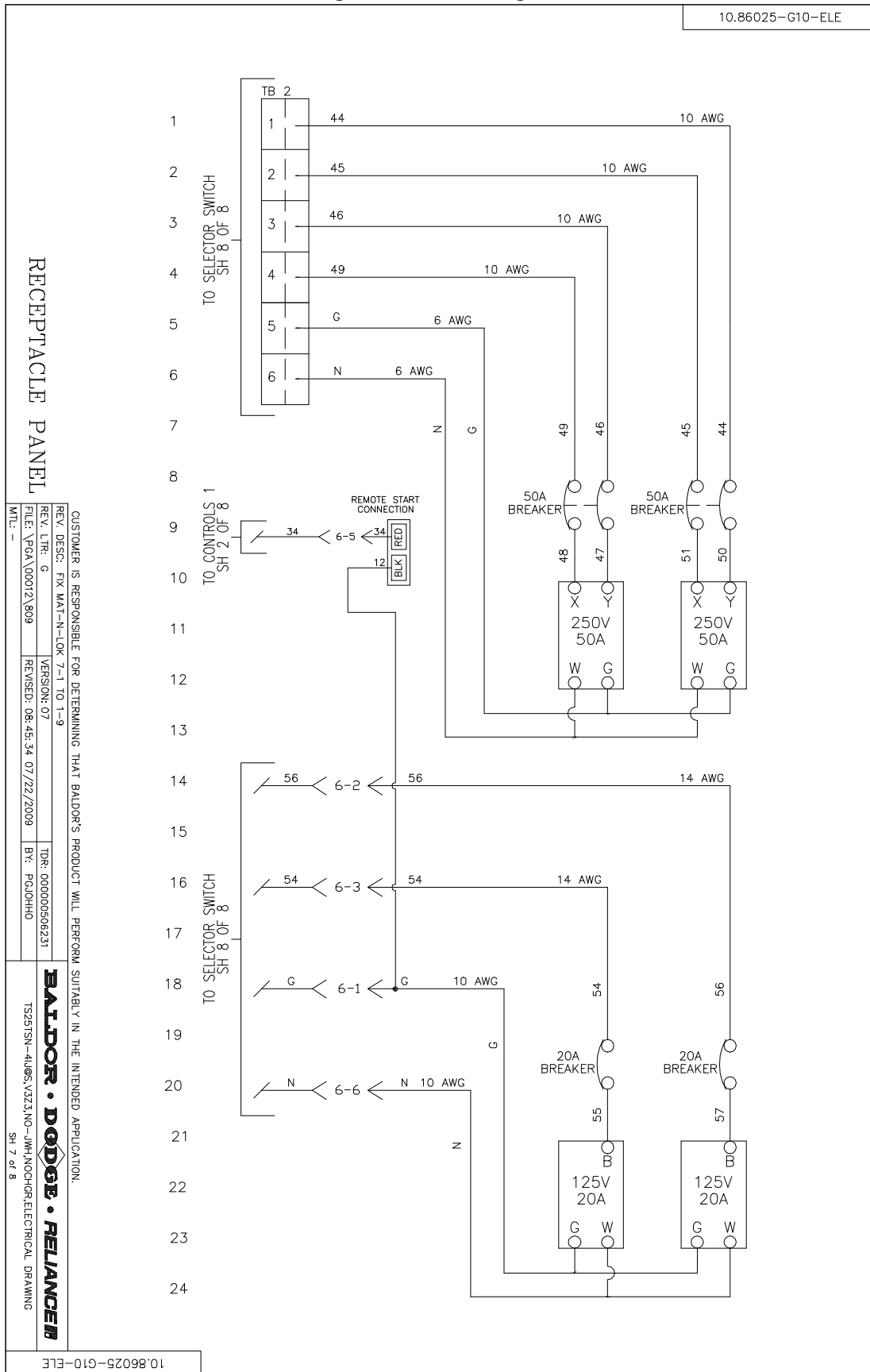
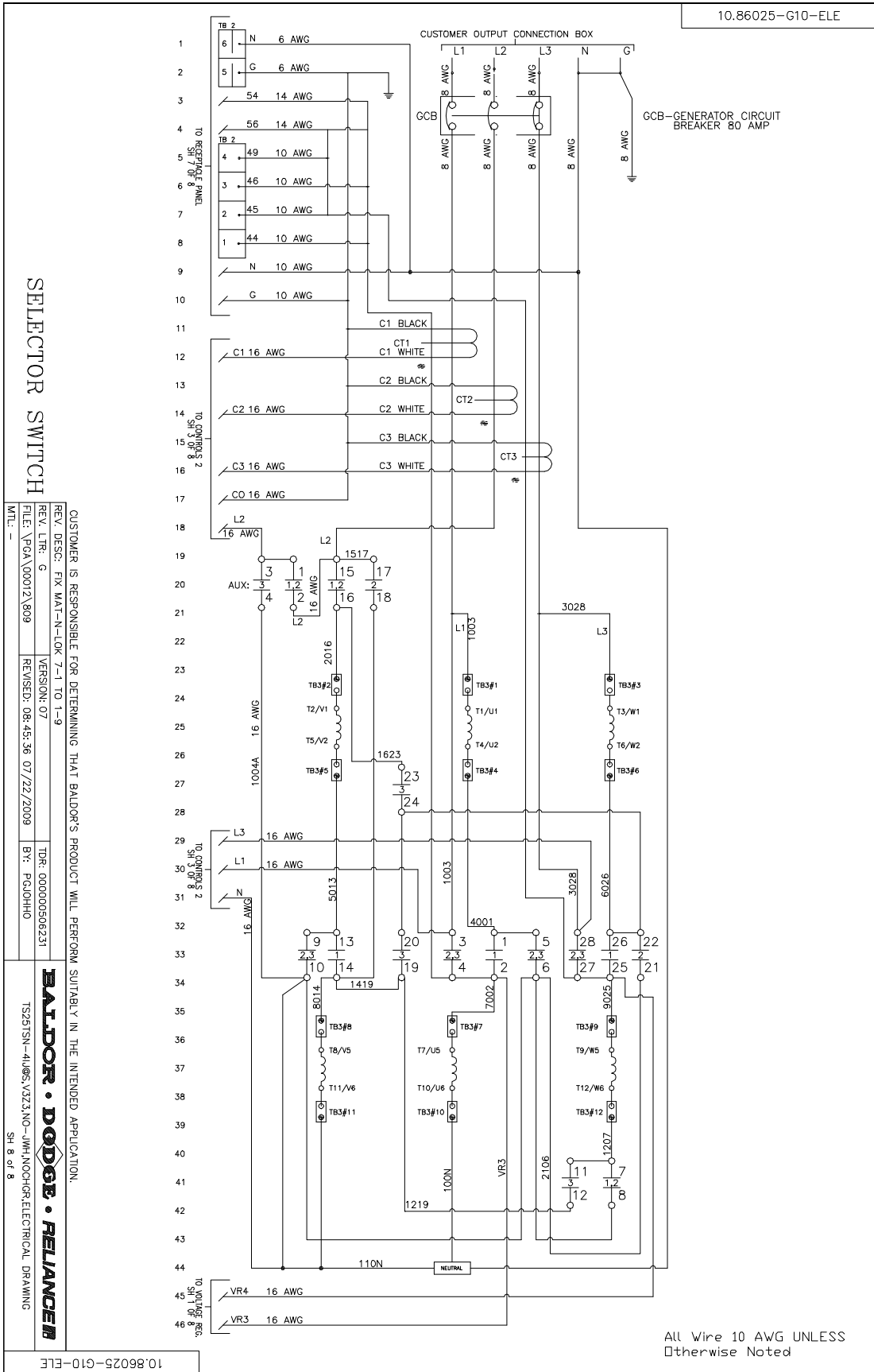

Figure A-6 TS25 Diagram



SELECTOR SWITCH

CUSTOMER IS RESPONSIBLE FOR DETERMINING THAT BALDOR'S PRODUCT WILL PERFORM SUITABLY IN THE INTENDED APPLICATION.
 REV. LTR: G
 REV. DESC: FIX MAT-N-LOK 7-1 TO 1-9
 VERSION: 07
 FILE: \P0A\00012\809
 REVISED: 08-45-36 07/22/2009
 TDR: 000000506231
 BR: PJOJHHD

BALDOR • DODGE • RELIANCE
 TS25TSN-4U085V323NO-JWH-INOCHER ELECTRICAL DRAWING
 SH 8 of 8

10.86025-G10-ELE

Figure A-8 TS35 Diagram

10.86035-G10-ELE

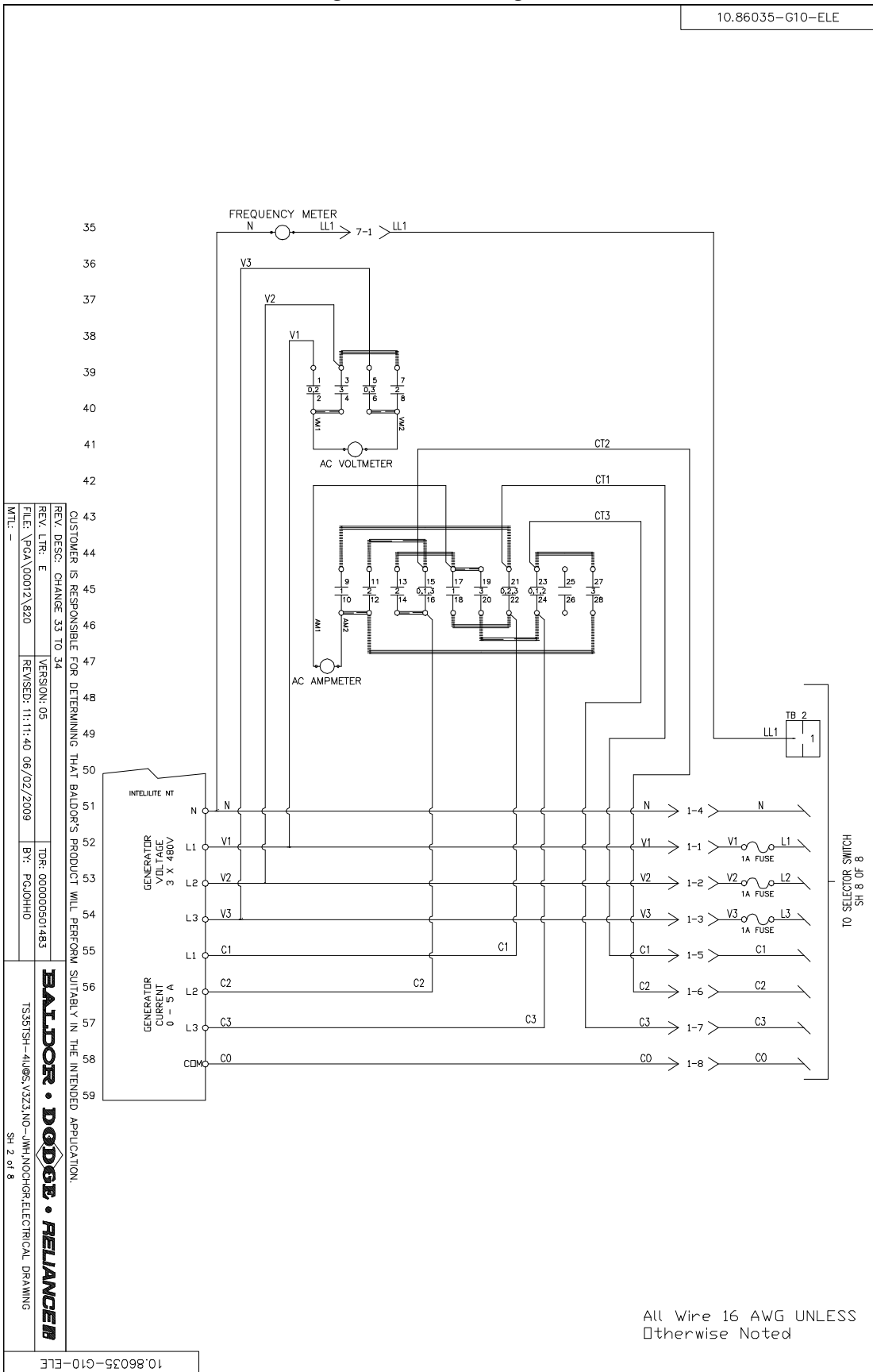
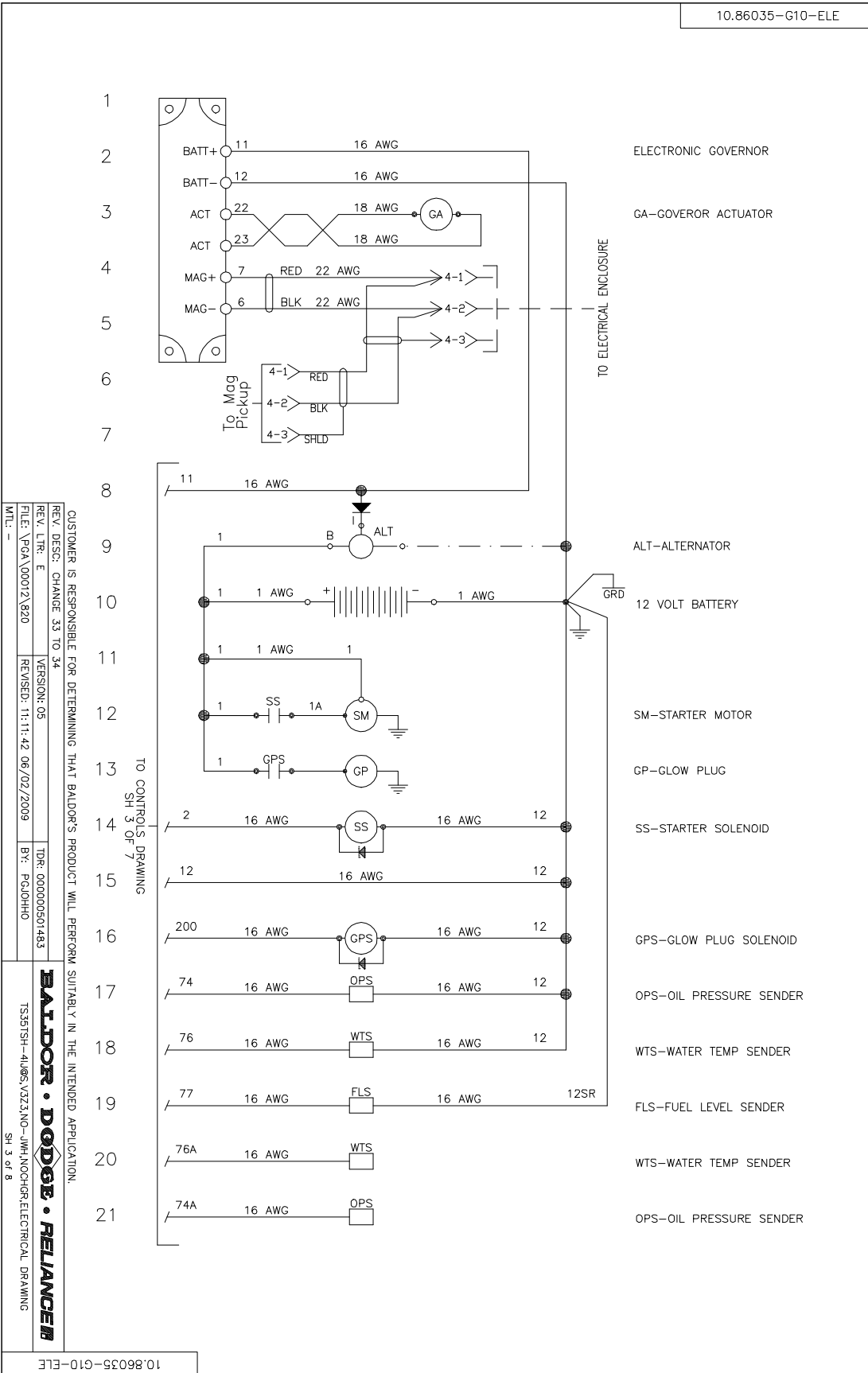

Figure A-9 TS35 Diagram

10.86035-G10-ELE



CUSTOMER IS RESPONSIBLE FOR DETERMINING THAT BALDOR'S PRODUCT WILL PERFORM SUITABLY IN THE INTENDED APPLICATION.

REV. DESG: CHANGE 33 TO 34
 REV. LTR: E
 FILE: \PGA\00012.820

VERSION: 05
 REVISED: 11-11-42 08/02/2009

TDR: 000000501483
 BY: PCJ0HHO

BALDOR • DODGE • RELIANCE

TS35TSH-4100S,V3Z3,NO-JMH,N00H6R,ELECTRICAL DRAWING

10.86035-G10-ELE

Figure A-10 TS35 Diagram

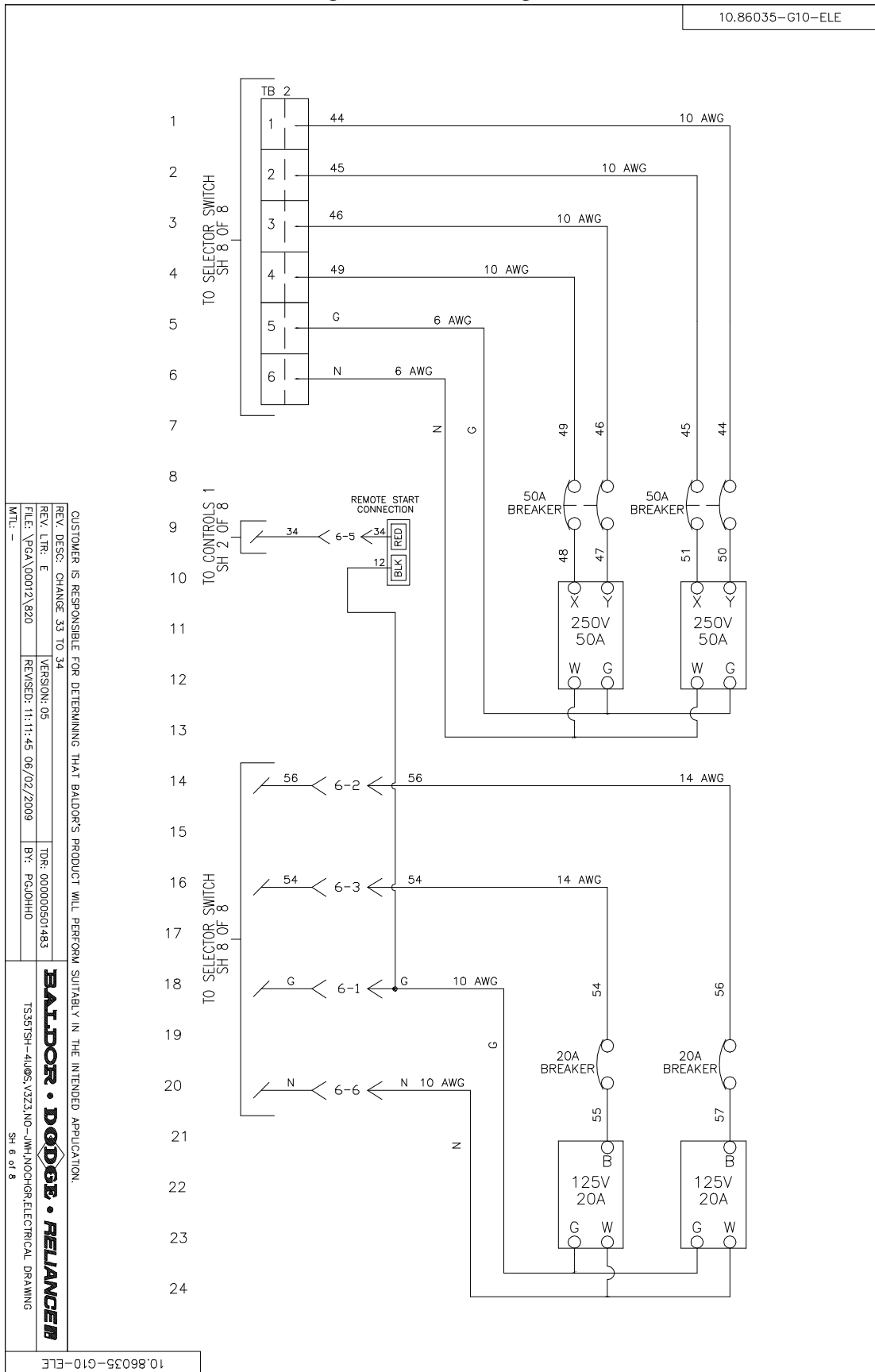
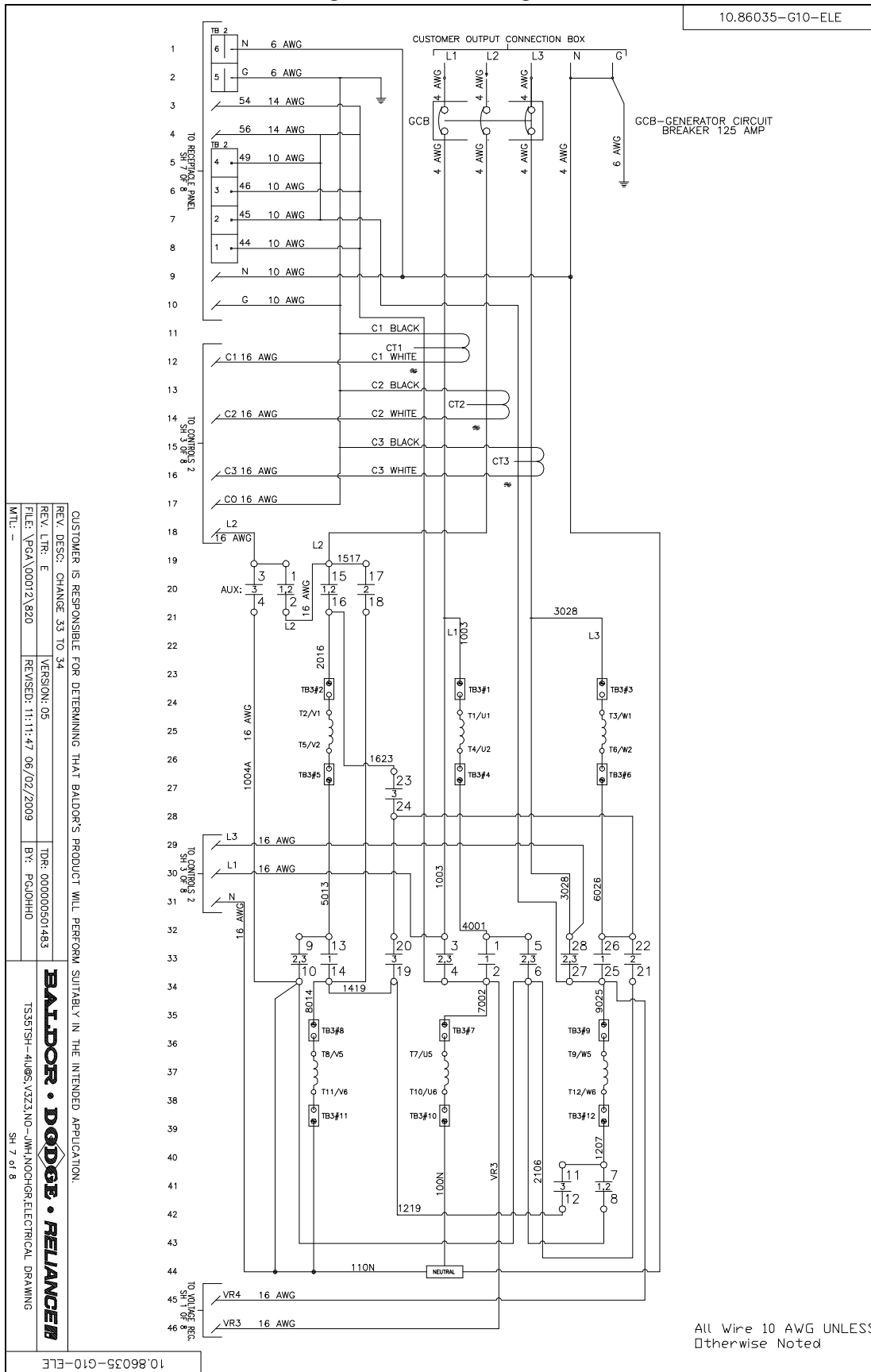

Figure A-11 TS35 Diagram



CUSTOMER IS RESPONSIBLE FOR DETERMINING THAT BALDOR'S PRODUCT WILL PERFORM SUITABLY IN THE INTENDED APPLICATION.

REV. DESG: CHANGE 33 TO 34	VERSION: 05
REV. LTR: E	BY: PCJ/DHH/D
FILE: \PGA\00012\820	REVISED: 11:11:47 08/02/2009

BALDOR • DODGE • RELIANCE

TS35TSH-4U0S.V3Z3.NO-JMH.NOOCH-R-ELECTRICAL DRAWING
SH 7 of 8

10.86035-G10-ELE

Figure A-12 TS35 Diagram

10.86035-G10-ELE

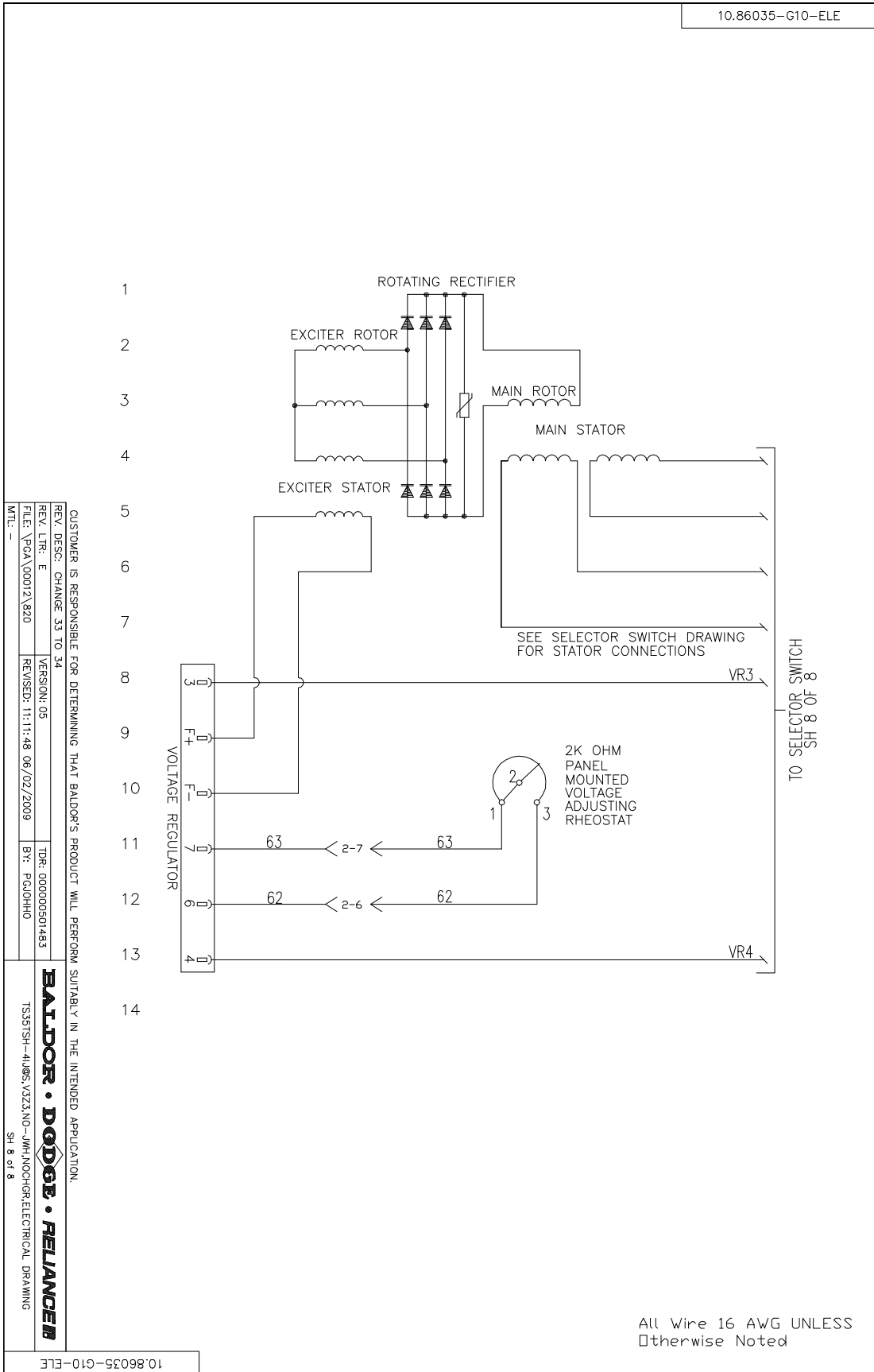

Figure A-14 TS45 Diagram

10.85045-G10-ELE

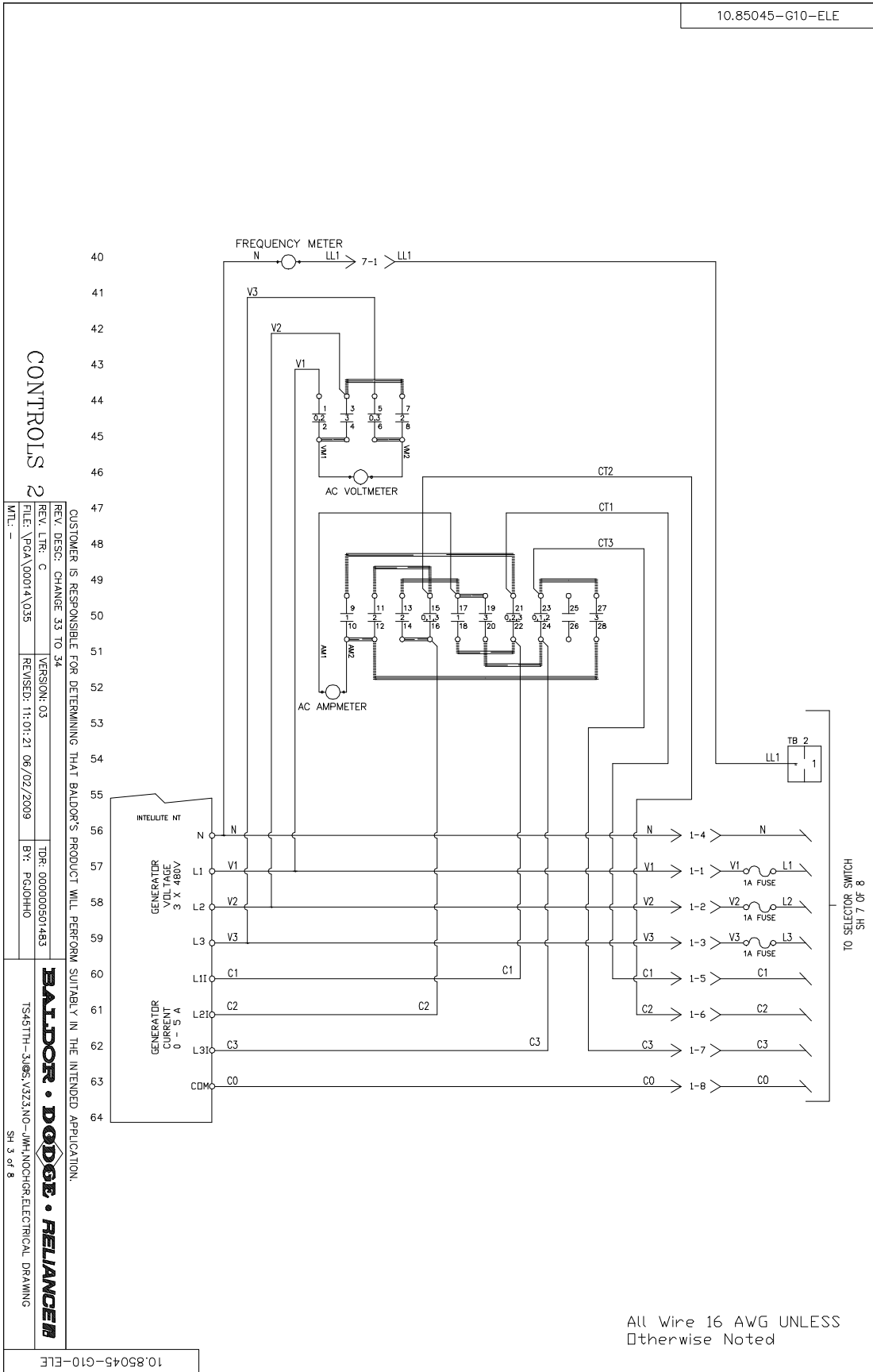

Figure A-19 TS45 Diagram

10.85045-G10-ELE

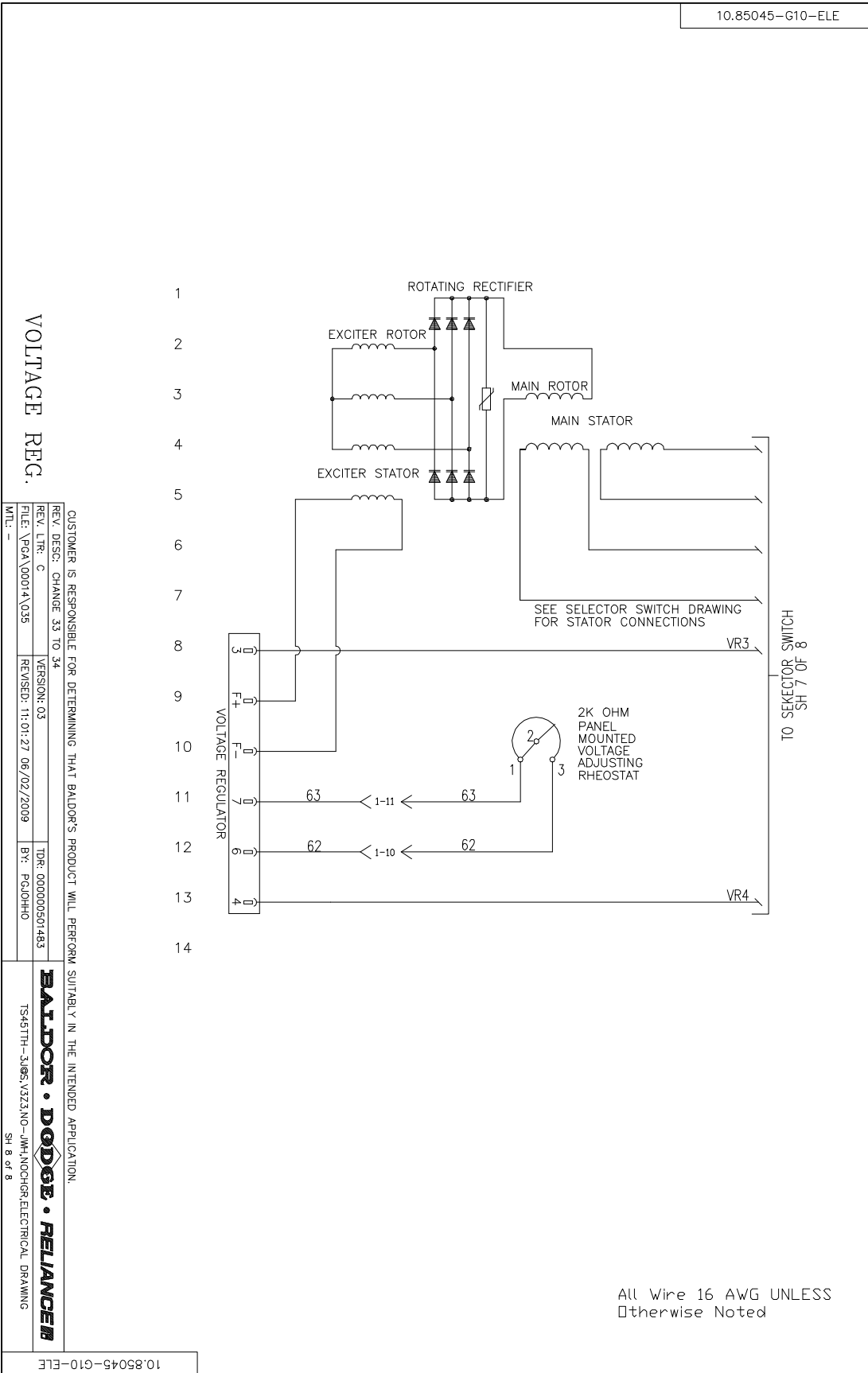
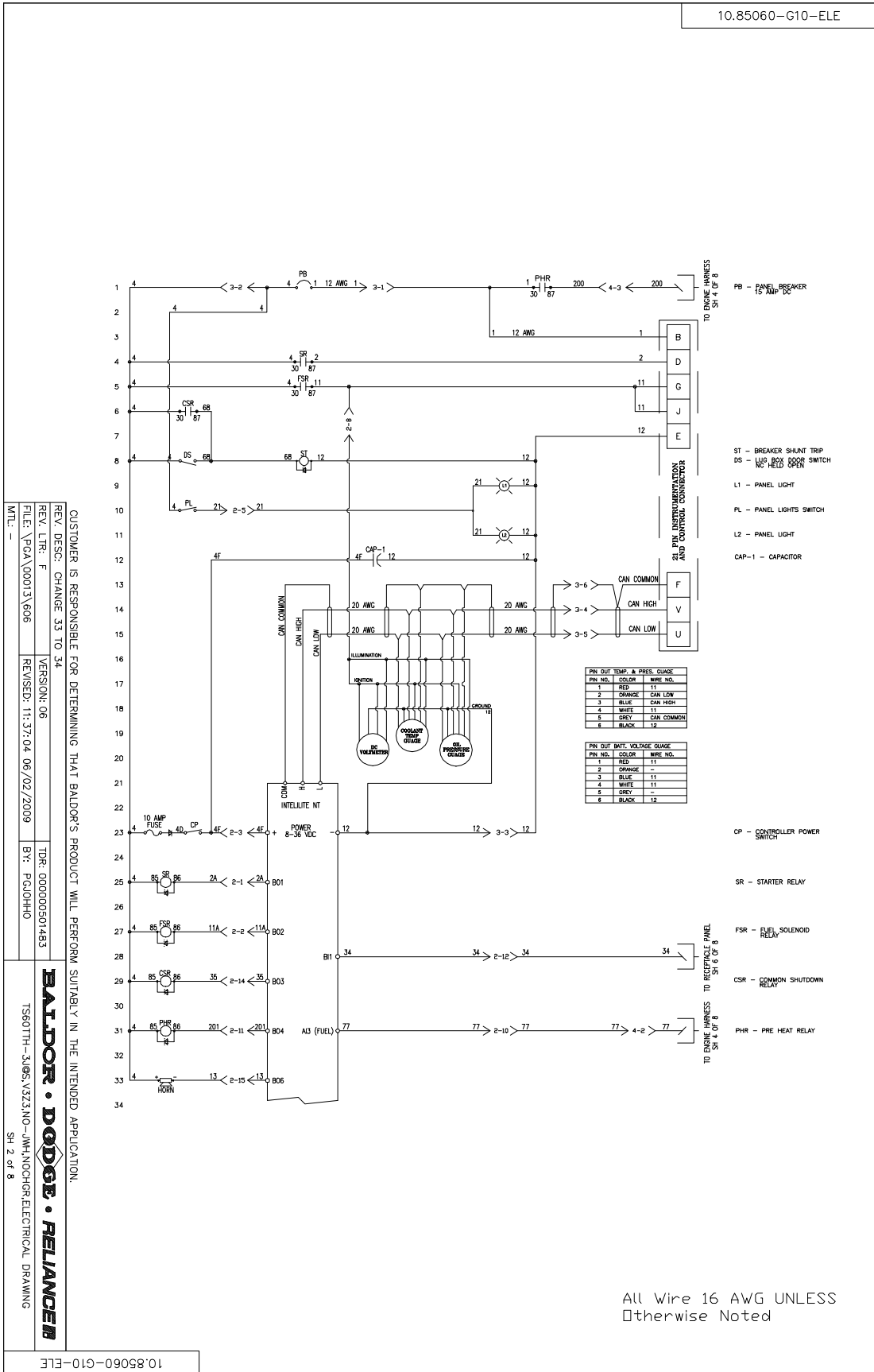

Figure A-20 TS60 Diagram

10.85060-G10-ELE



All Wire 16 AWG UNLESS
 Otherwise Noted

Figure A-21 TS60 Diagram

10.85060-G10-ELE

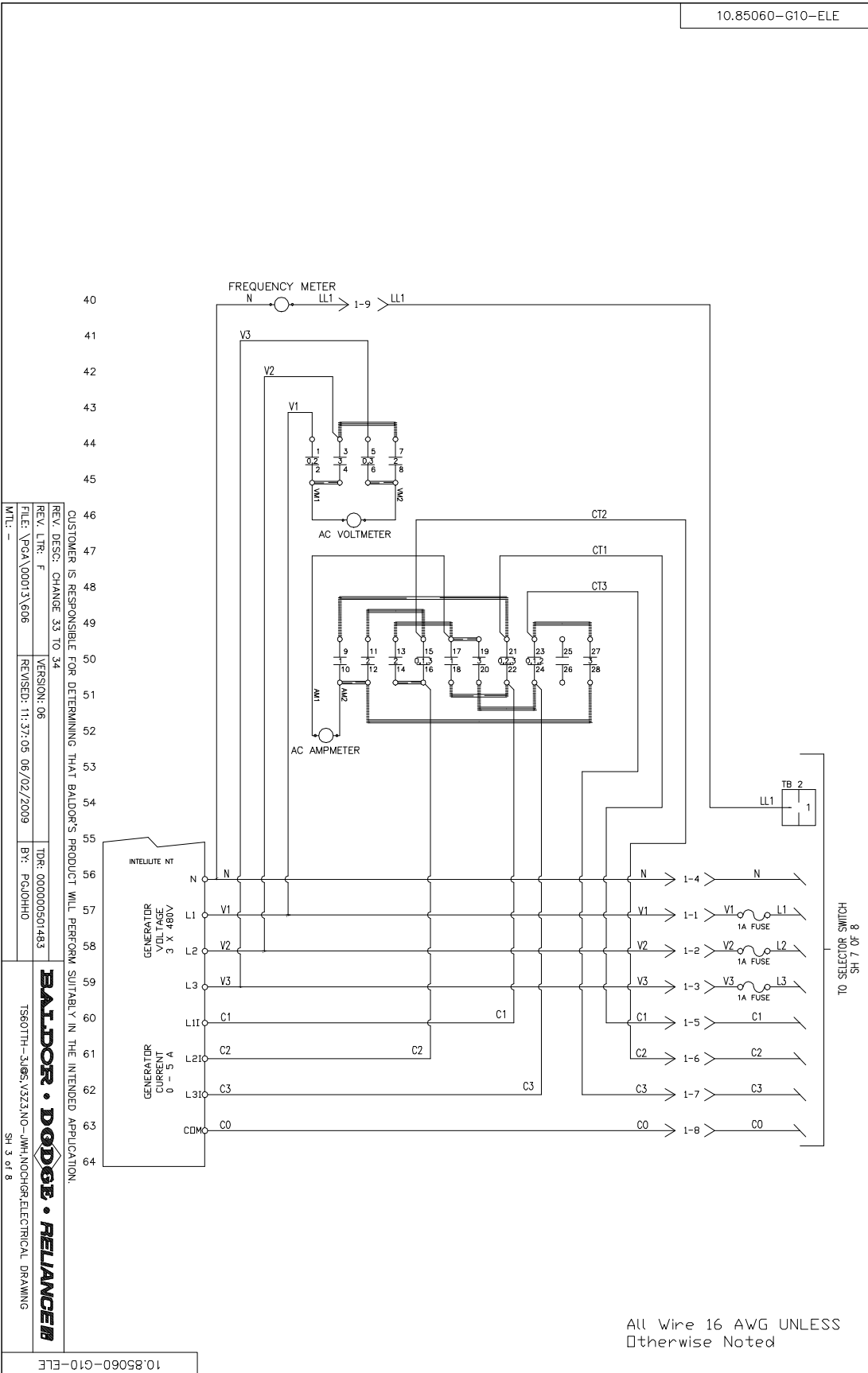

REV. DESG: CHANGE 33 TO 34
 REV. LTR: F
 FILE: \PGA\00013\606
 VERSION: 06
 REVISED: 11:37:05 08/02/2009
 TDR: 000000501483
 BY: PCJ0HHQ

BALDOR • DODGE • RELIANCE
 TS60TH-310S.V3Z3.NO-JWH.NOCHELECTRICAL DRAWING
 SH 3 OF 8

10.85060-G10-ELE

All Wire 16 AWG UNLESS
 Otherwise Noted

Figure A-24 TS60 Diagram

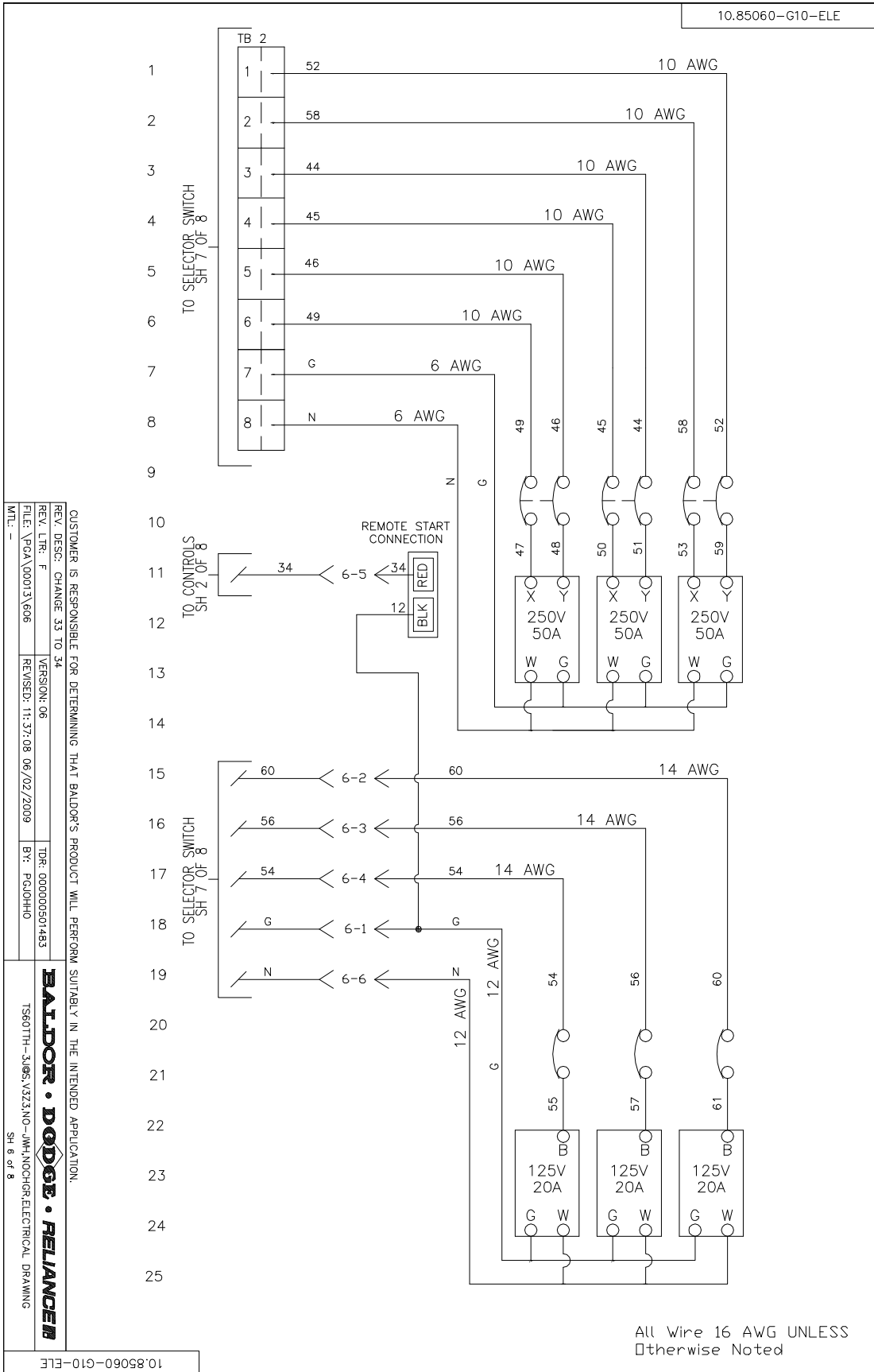

CUSTOMER IS RESPONSIBLE FOR DETERMINING THAT BALDOR'S PRODUCT WILL PERFORM SUITABLY IN THE INTENDED APPLICATION.

REV. LTR: F
 REV. DESC: CHANGE 33 TO 34
 FILE: \PDA\00013\696

VERSION: 06
 REVISED: 11:37:08 06/02/2009
 B1: PLOJHDO

MTL: -

BALDOR • DODGE • RELIANCE

TS60TH-3,0S,V3Z3,NO-JWH,NOCHRELECTRICAL DRAWING
 SH 8 of 8

10.85060-G10-ELE

Figure A-26 TS60 Diagram

10.85060-G10-ELE

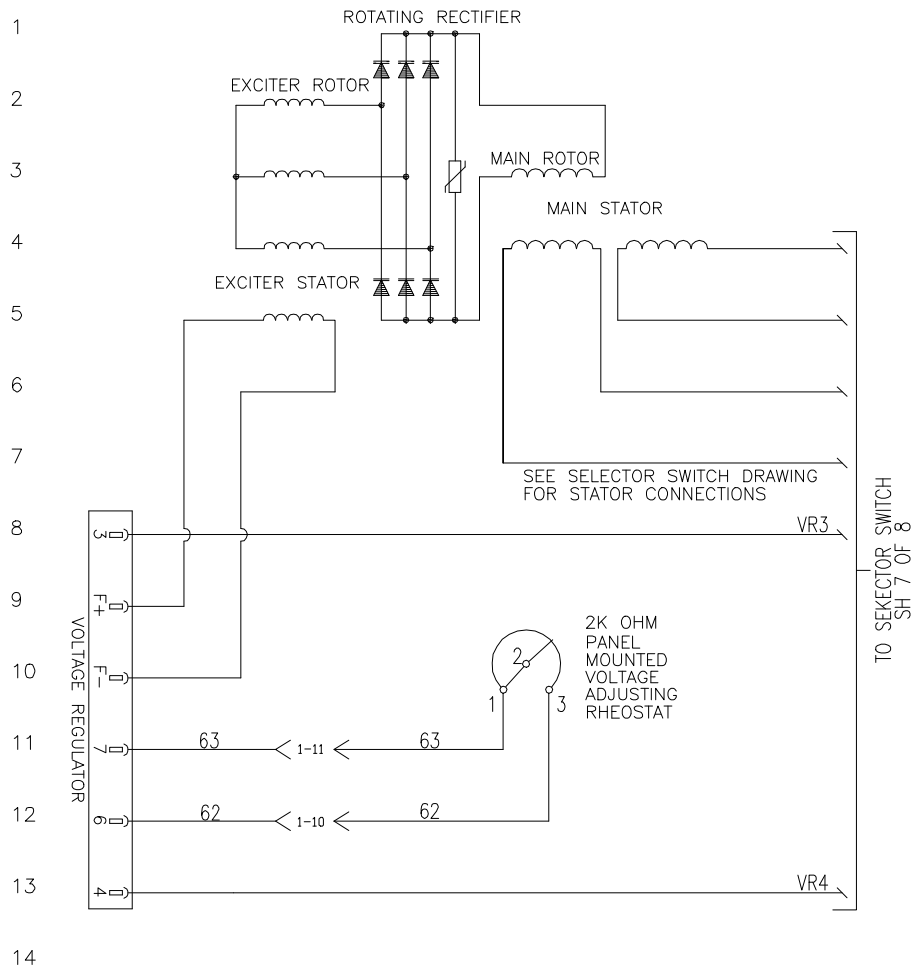

All Wire 16 AWG UNLESS
 Otherwise Noted

CUSTOMER IS RESPONSIBLE FOR DETERMINING THAT BALDOR'S PRODUCT WILL PERFORM SUITABLY IN THE INTENDED APPLICATION.
 REV. DESC: CHANGE 33 TO 34
 REV. LTR: F
 FILE: \P&A\00013\606
 MTL: -
 VERSION: 06
 REVISED: 11:37:10 08/02/2009
 TOR: 00000501483
 BR: P&JDDHO

BALDOR • DODGE • RELIANCE
 TS60TH-3,05,V3Z3,NO-4WH,NOCHGR,ELECTRICAL DRAWING
 SH 8 of 8

10.85060-G10-ELE

Figure A-27 TS80 Diagram

10.85080-G10-ELE

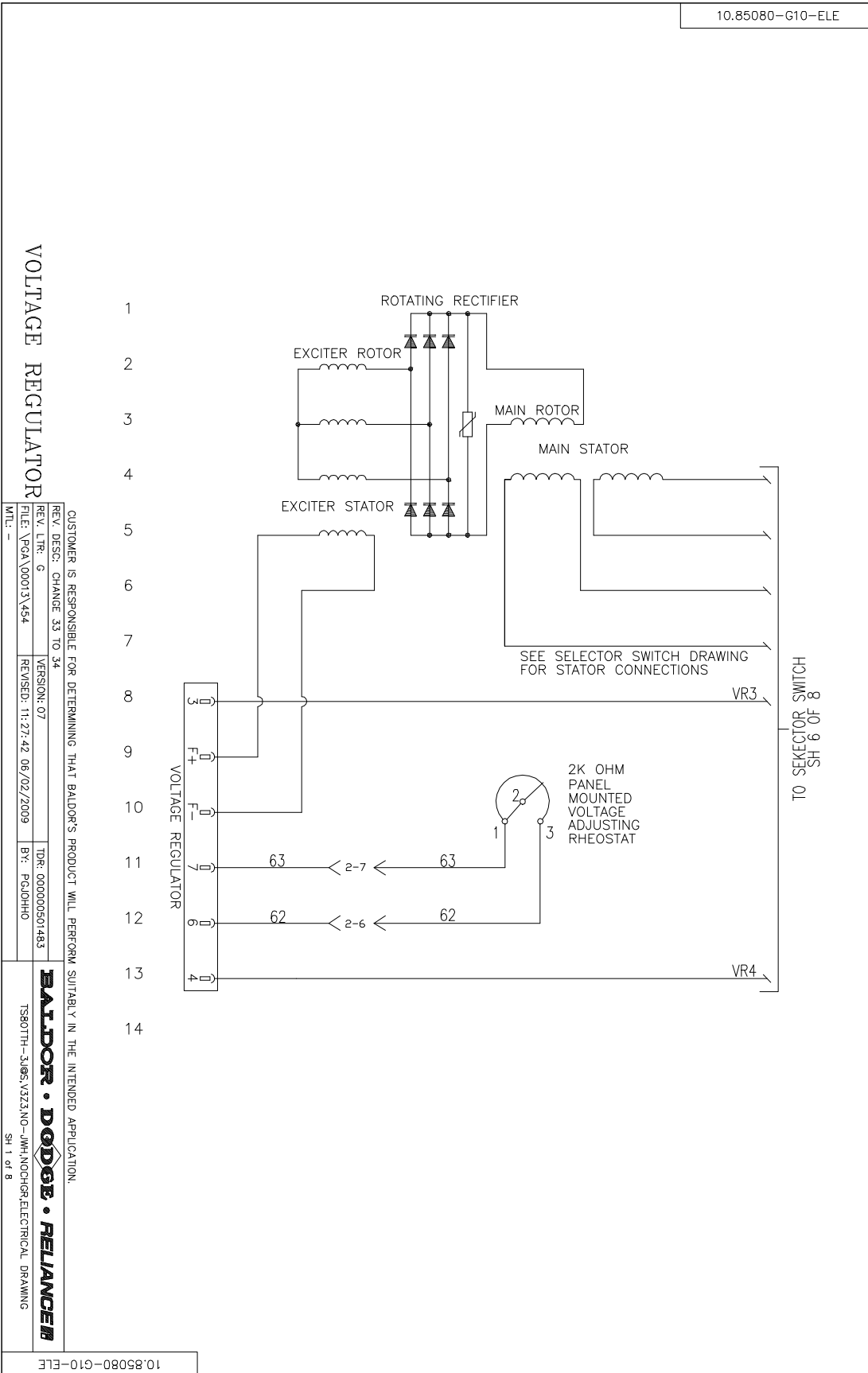

VOLTAGE REGULATOR

CUSTOMER IS RESPONSIBLE FOR DETERMINING THAT BALDOR'S PRODUCT WILL PERFORM SUITABLY IN THE INTENDED APPLICATION.

REV. DESG: CHANGE 33 TO 34	VERSION: 07
REV. LTR: G	REVISED: 11:27:42 08/02/2009
FILE: \PGA\00013\454	BY: PCJ0HH0
MTL: -	TDR: 000000501483

BALDOR • DODGE • RELIANCE

TS80TH-310S.V3Z3.NG-JMH.NOOHR.ELECTRICAL DRAWING

10.85080-G10-ELE

Figure A-28 TS80 Diagram

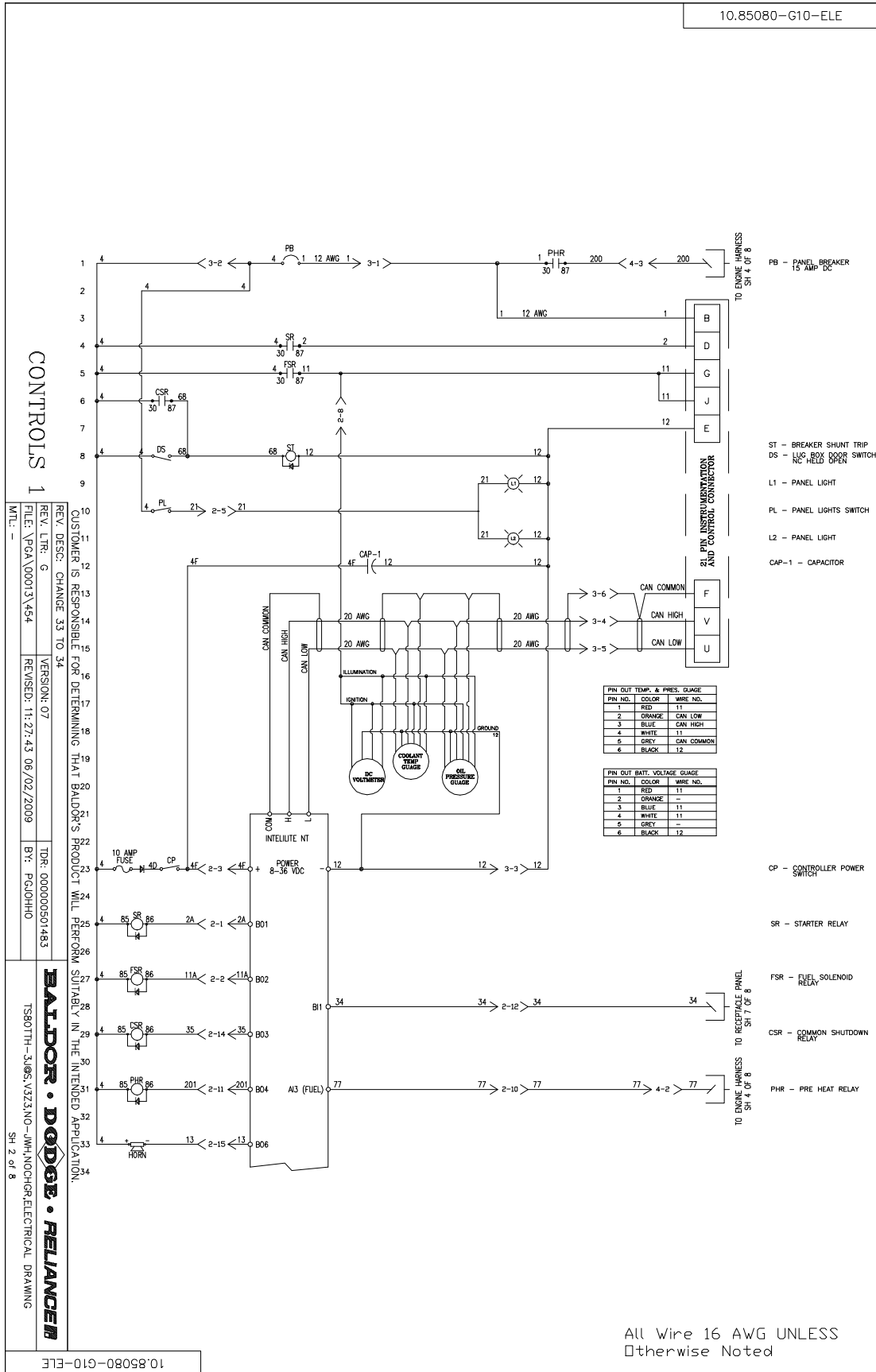
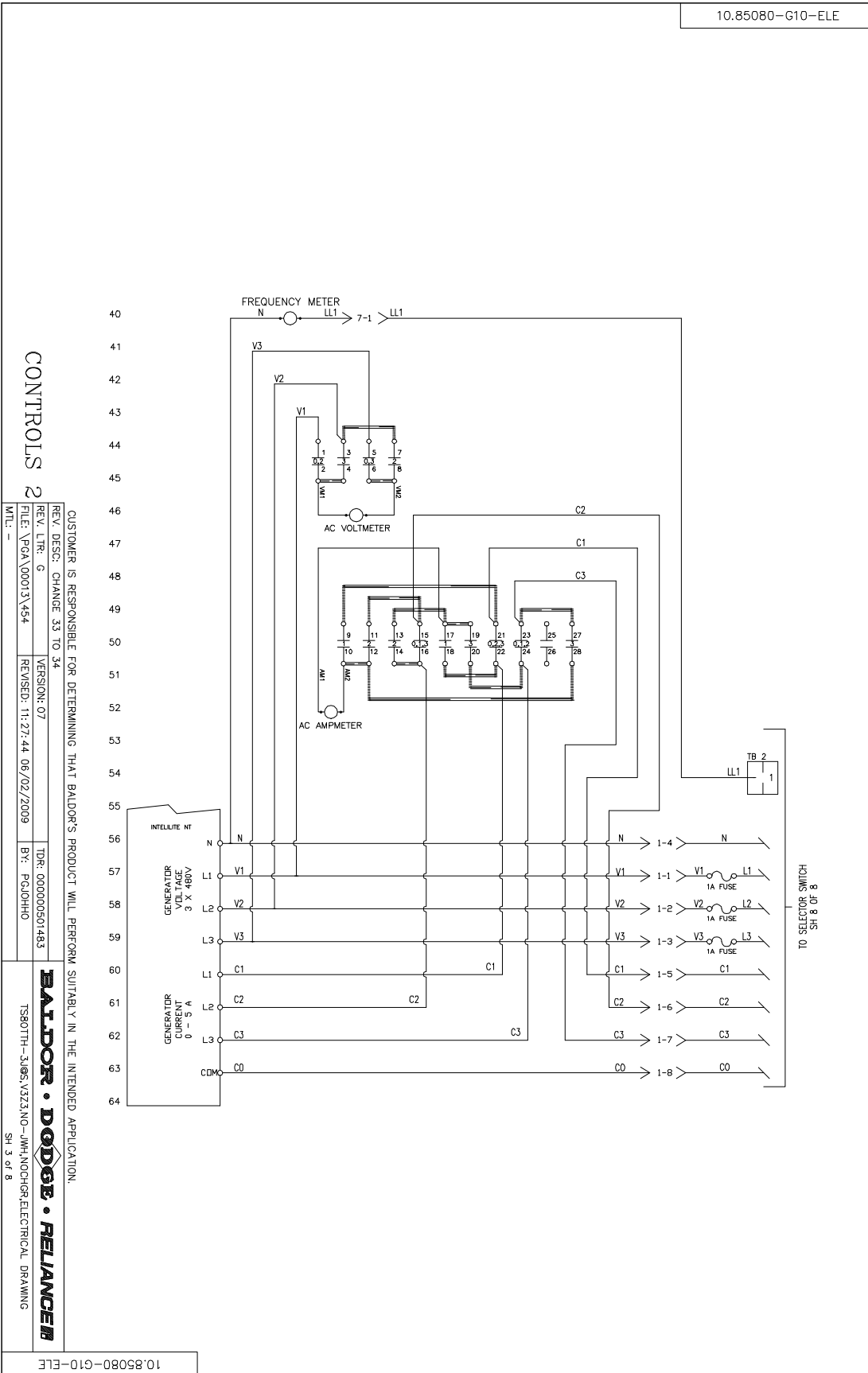

Figure A-29 TS80 Diagram

10.85080-G10-ELE



CONTROLS 2

CUSTOMER IS RESPONSIBLE FOR DETERMINING THAT BALDOR'S PRODUCT WILL PERFORM SUITABLY IN THE INTENDED APPLICATION.
 REV. DESG: CHANGE 33 TO 34
 REV. LTR: G
 FILE: \PGA\00013\454
 VERSION: 07
 REVISED: 11-27-44 08/02/2009
 MTL: -
 TOR: 000000501483
 BY: PCJ0HHO

BALDOR • DOUGLASS • RELIANCE
 TS80TH-310S.V3Z3.NG-JMH.NOCHELECTRICAL DRAWING
 SH 3 OF 8

10.85080-G10-ELE

Figure A-30 TS80 Diagram

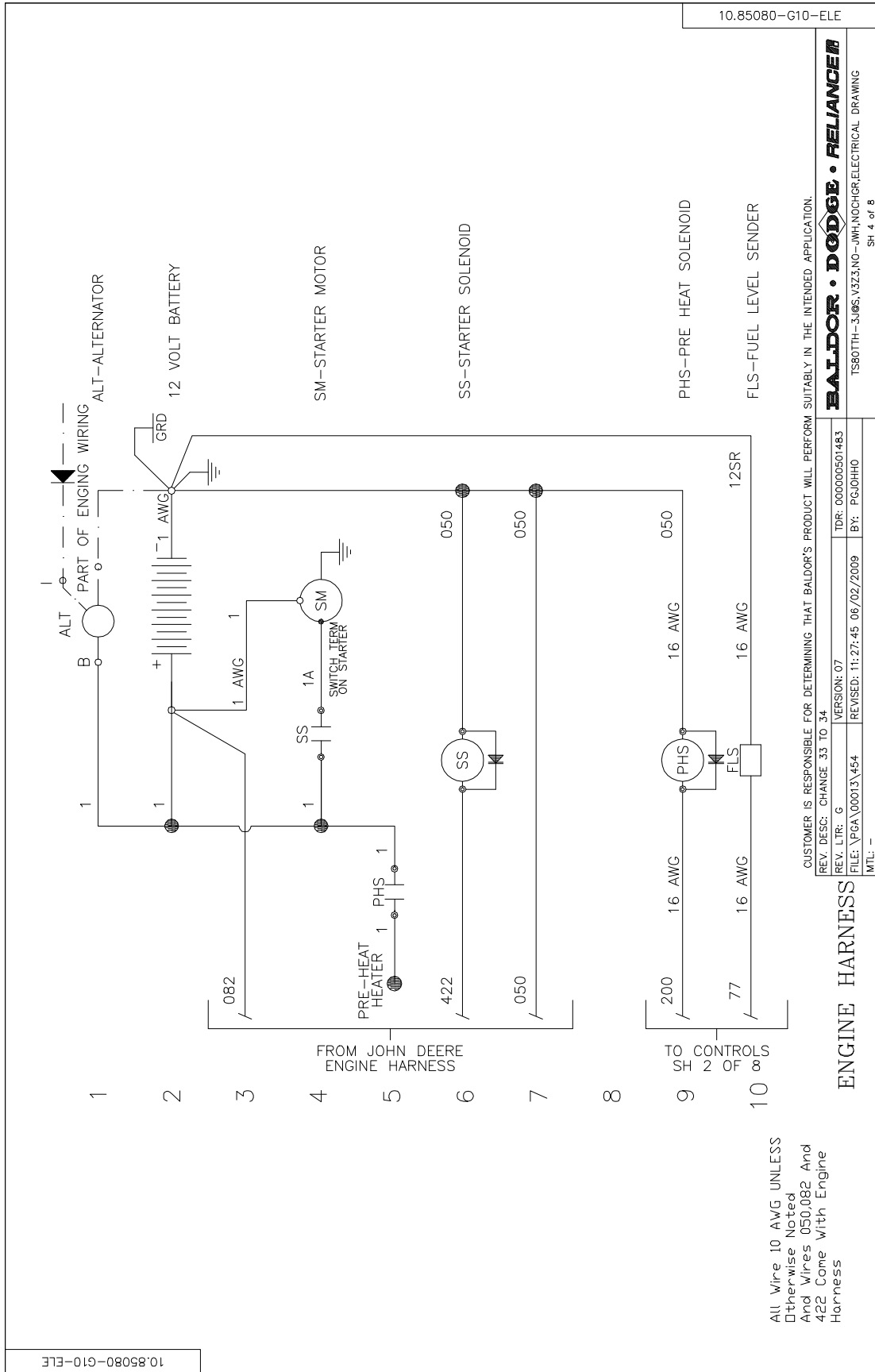

10.85080-G10-ELE

CUSTOMER IS RESPONSIBLE FOR DETERMINING THAT BALDOR'S PRODUCT WILL PERFORM SUITABLY IN THE INTENDED APPLICATION.

REV. DESC: CHANGE 33 TO 34	TDR: 00000501483
REV. LTR: G	BY: PGJ0HHO
FILE: \PGA\00013\454	REVISED: 11/27/45 06/02/2009
MTL: -	

BALDOR • DODGE • RELIANCE
 TS80TH-3J08-V3Z3.NO-JWH,NOCHGR,ELECTRICAL DRAWING
 SH 4 of 8

ENGINE HARNESS

All Wire 10 AWG UNLESS
 Otherwise Noted
 And Wires 050,082 And
 422 Come With Engine
 Harness

10.85080-G10-ELE

Figure A-34 TS130

10.85130-G20-ELE

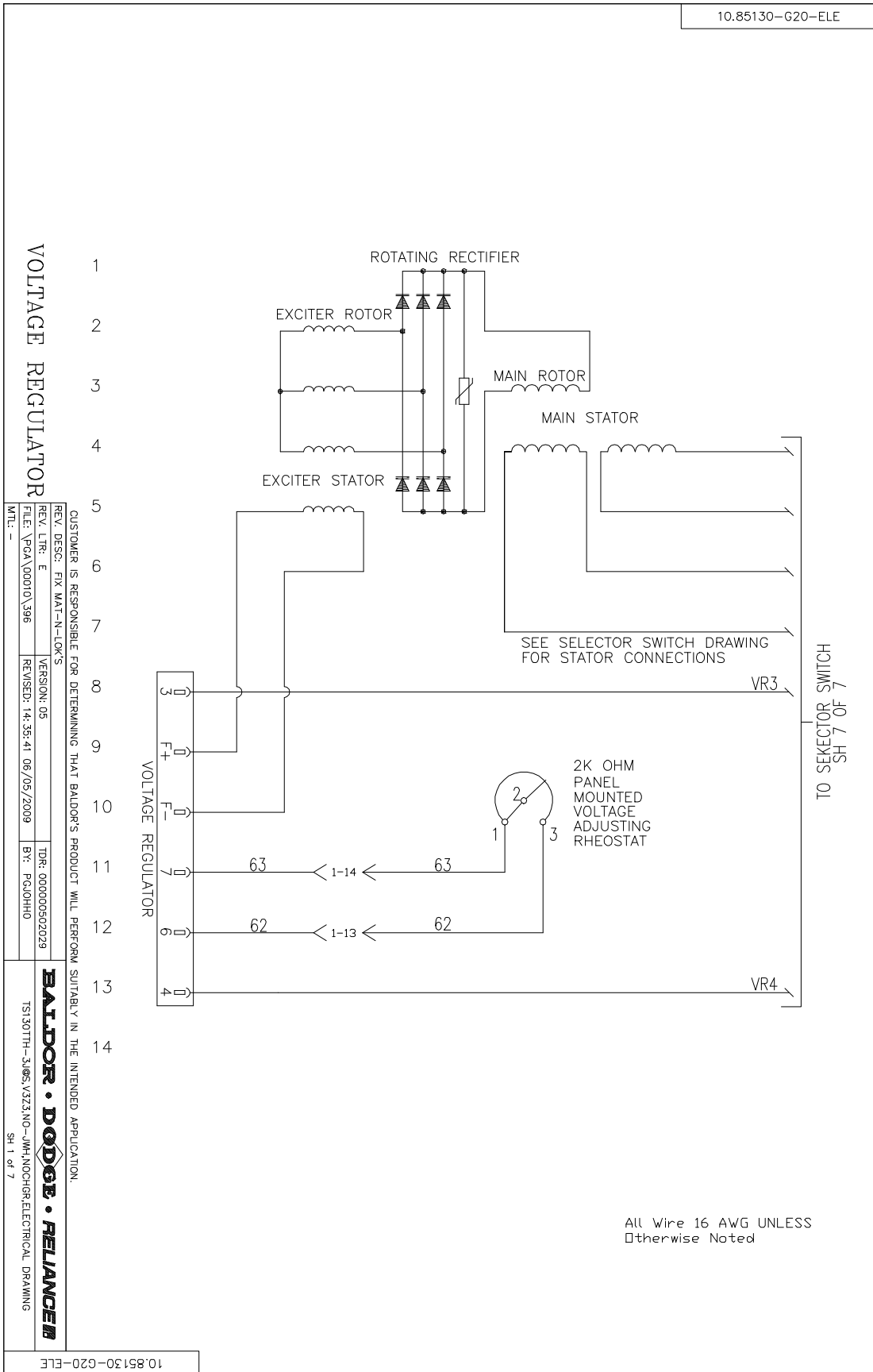

VOLTAGE REGULATOR

CUSTOMER IS RESPONSIBLE FOR DETERMINING THAT BALDOR'S PRODUCT WILL PERFORM SUITABLY IN THE INTENDED APPLICATION.

REV. LTR: E

FILE: VPGA\00010\396

VERSION: 05

REVISED: 14:35:41 06/05/2009

DR: 00000502029

BR: PGJHHO

MTL: -

BALDOR • DODGE • RELIANCE

TS130TH-3J05; V3Z3NO-JWH; NOCHGR; ELECTRICAL DRAWING

SH 1 of 7

10.85130-G20-ELE

Figure A-35 TS130

10.85130-G20-ELE

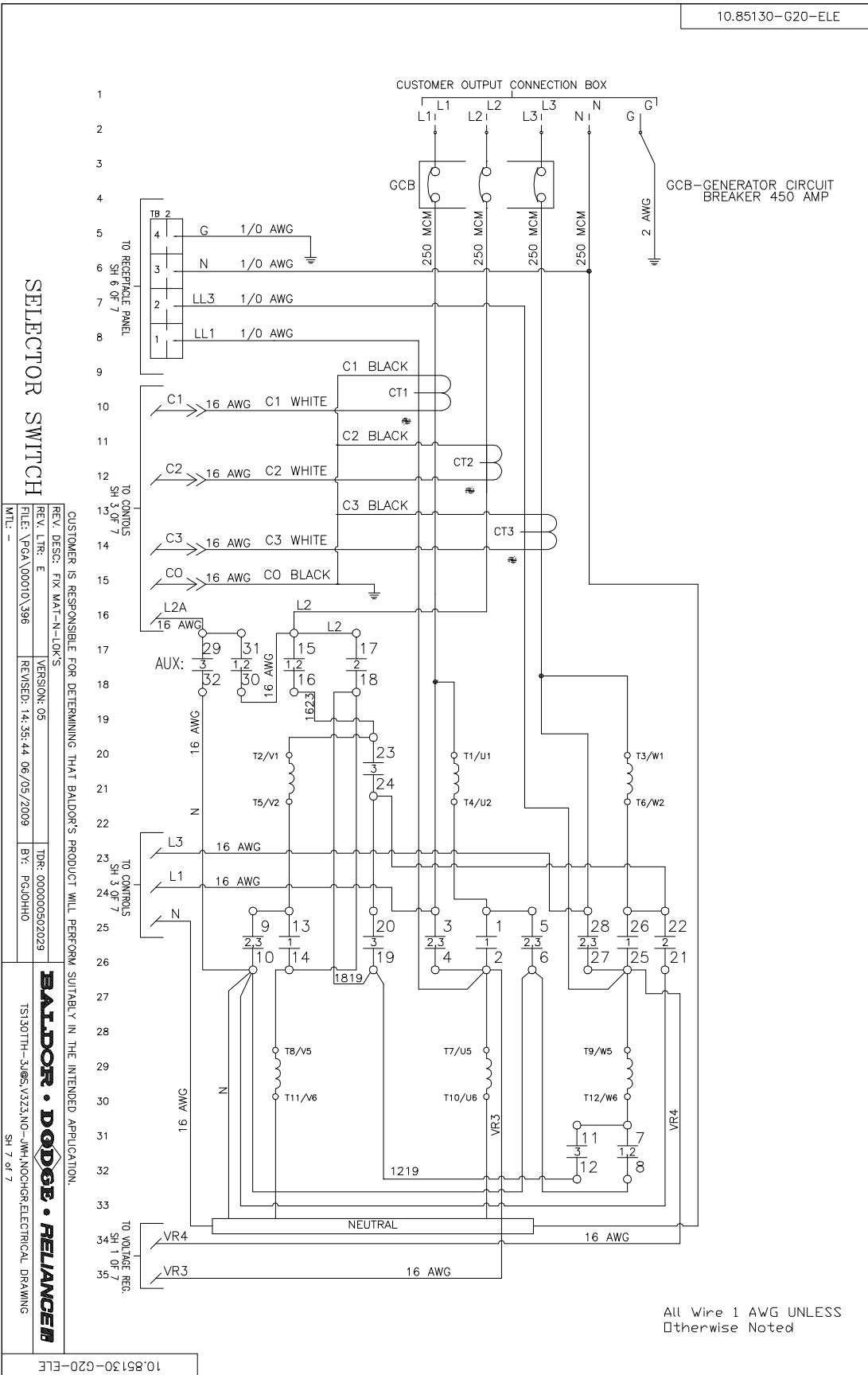

SELECTOR SWITCH

CUSTOMER IS RESPONSIBLE FOR DETERMINING THAT BALDOR'S PRODUCT WILL PERFORM SUITABLY IN THE INTENDED APPLICATION.

REV. DESG: FIX MAT-N-LOKS
 REV. LTR: E
 FILE: \PGA\00010\396
 VERSION: 05
 REVISED: 14:35:44 06/05/2009
 TOR: 00000502029
 BY: PGIJHD

BALDOR • DODGE • RELIANCE

TS130TH-3J05-V3Z3-NO-JWH-NOCHGR-ELECTRICAL DRAWING
 SH 7 of 7

All Wire 1 AWG UNLESS
 otherwise Noted

10.85130-G20-ELE

Figure A-36 TS130

10.85130-G20-ELE

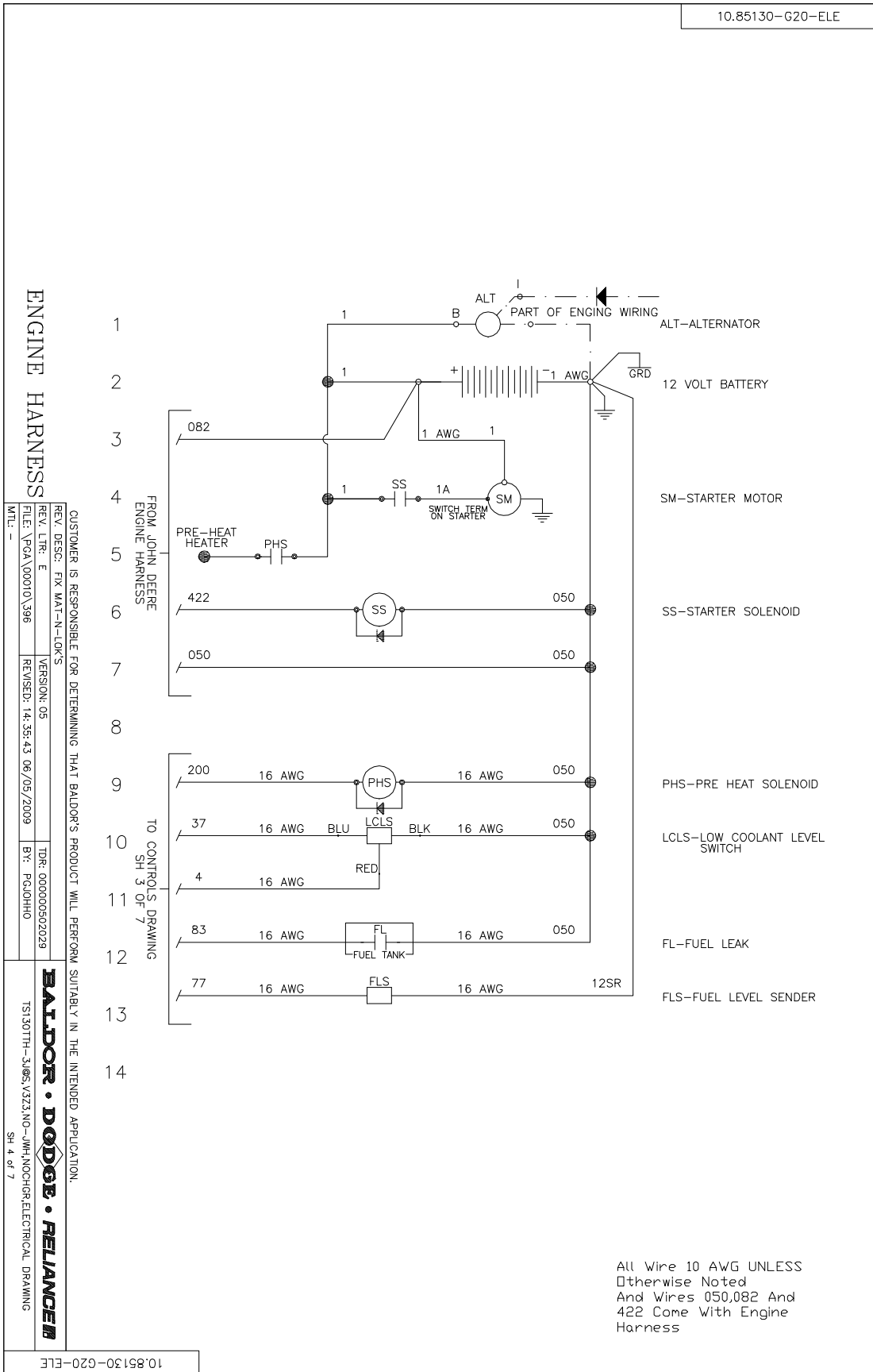

ENGINE HARNESS

REV. LTR: E
 FILE: PQA\00010\396
 MTL: -
 VERSION: 05
 REVISED: 14:35:43 06/05/2009
 TOR: 00000502029
 BR: PGIJHHO

CUSTOMER IS RESPONSIBLE FOR DETERMINING THAT BALDOR'S PRODUCT WILL PERFORM SUITABLY IN THE INTENDED APPLICATION.

BALDOR • DODGE • RELIANCE

TS130TH-3J05; V323NO-JWH; NOCHG; ELECTRICAL DRAWING
 SH 4 of 7

All Wire 10 AWG UNLESS
 Otherwise Noted
 And Wires 050,082 And
 422 Come With Engine
 Harness

10.85130-G20-ELE

Figure A-38 TS130

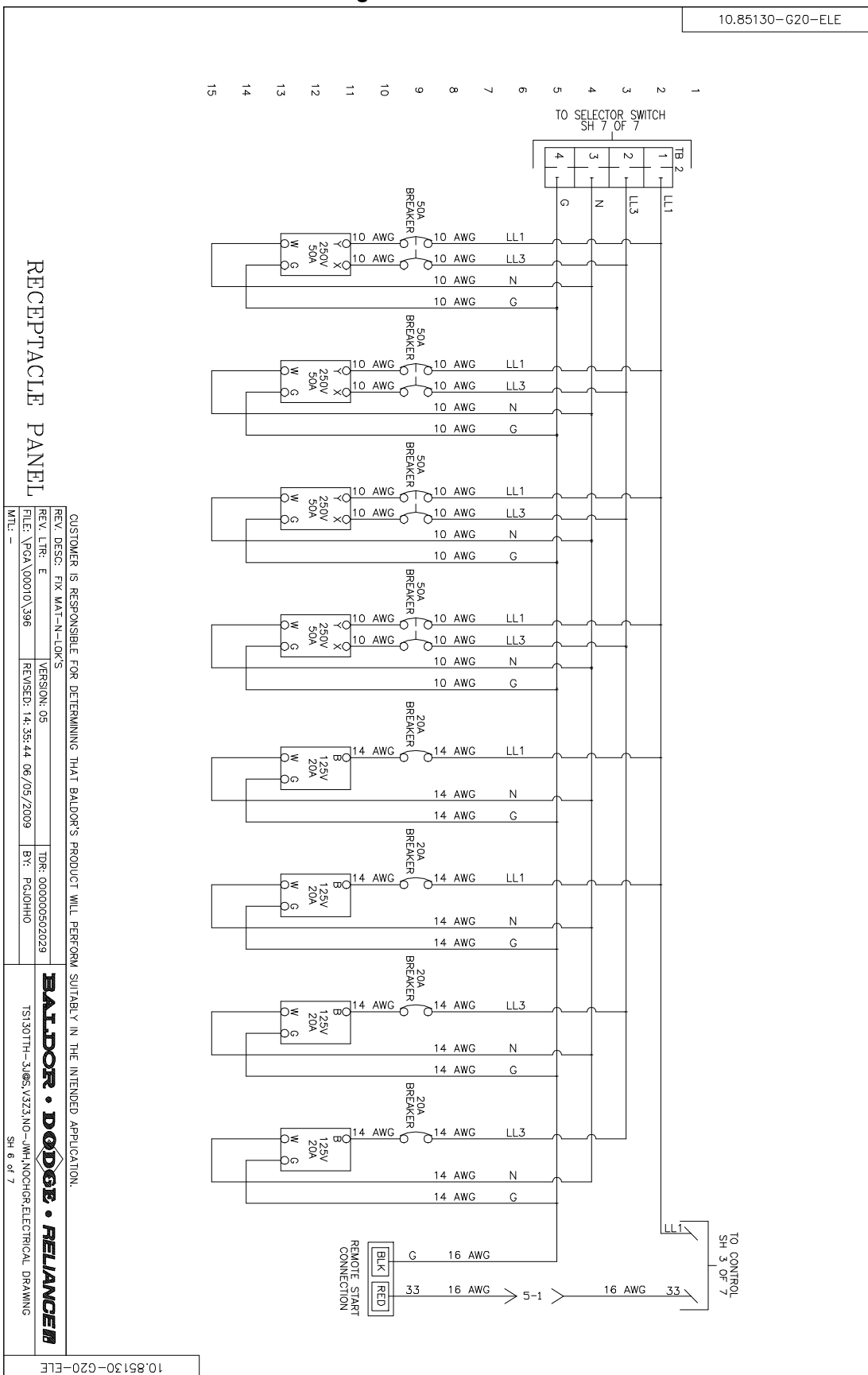

Figure A-39 TS130

10.85130-G20-ELE

CONNECTOR #2
12 PIN

PIN NUMBER	WIRE NUMBER
1	2A
2	11A
3	4F
4	21
5	11
6	77
7	201
8	33
9	37
10	35
11	83
12	-

CONNECTOR #4
6 PIN

PIN NUMBER	WIRE NUMBER
1	-
2	77
3	200
4	37
5	4
6	83

CONNECTOR #5
6 PIN

PIN NUMBER	WIRE NUMBER
1	33
2	LL1
3	G
4	N
5	L1
6	-

CONNECTOR #3
6 PIN

PIN NUMBER	WIRE NUMBER
1	1
2	4
3	12
4	CAN HIGH
5	CAN LDW
6	CAN CDM

CONNECTOR #1
15 PIN

PIN NUMBER	WIRE NUMBER
1	V1
2	V2
3	V3
4	N
5	C1
6	C2
7	C3
8	C0
9	-
10	-
11	-
12	LL1
13	62
14	63
15	-

CAN BUS CONNECTIONS

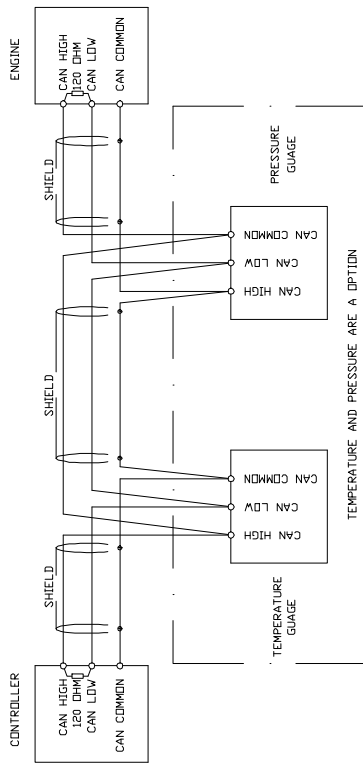

CAN BUS CABLES MUST BE CONNECTED IN SERIES FROM ONE COMPONENT TO THE NEXT (NO STUBS, NO STARS, AND NO BRANCHES). BOTH ENDS REQUIRE A 120 OHM TERMINATING RESISTOR WHICH MAY BE INTERNAL TO THE ENDING DEVICE. DO NOT ADD RESISTORS UNLESS SHOWN IN DRAWING AS ILLUSTRATED ABOVE.

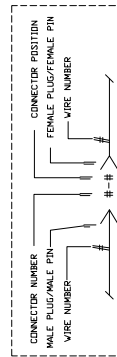

CUSTOMER IS RESPONSIBLE FOR DETERMINING THAT BALDOR'S PRODUCT WILL PERFORM SUITABLY IN THE INTENDED APPLICATION.

REV. DESC: FIX MAT-N-LOK'S	VERSION: 05
REV. LTR: E	TDR: 000000502029
FILE: \PGA\00010\396	REVISED: 14:35:43 06/05/2009
MTL: --	BY: PGJHHO

BALDOR • DODGE • RELIANCE
TS130TH-3,UBS,V3Z3,NO-JWH,NOCHGR,ELECTRICAL DRAWING
SH 5 of 7

10.85130-G20-ELE

Figure A-40 TS175

10.85175-G20-ELE

VOLTAGE REGULATOR

CUSTOMER IS RESPONSIBLE FOR DETERMINING THAT BALDOR'S PRODUCT WILL PERFORM SUITABLY IN THE INTENDED APPLICATION.
 REV. DESC: CHANGE BREAKER WIRE SIZE
 REV. LTR: C
 VERSION: 03
 FILE: VPA\00013\713
 REVISED: 08-51:08 07/31/2009
 TDR: 00000506231
 BR: PGJHHO
 MTL: -

BALDOR • DODGE • RELIANCE
 TS175TH-3J05; V323NO-JWH; NOCHRG; ELECTRICAL DRAWING
 SH 1 of 7

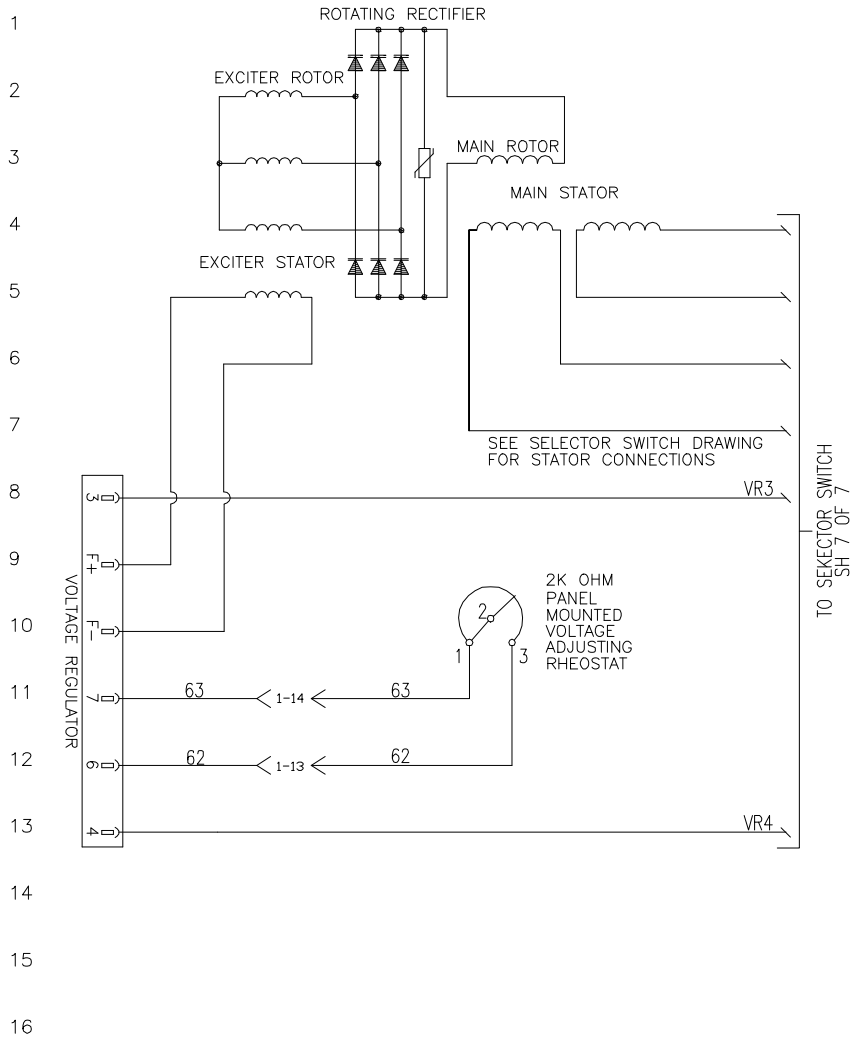

All Wire 16 AWG UNLESS
 Otherwise Noted

10.85175-G20-ELE

Figure A-42 TS175

10.85175-G20-ELE

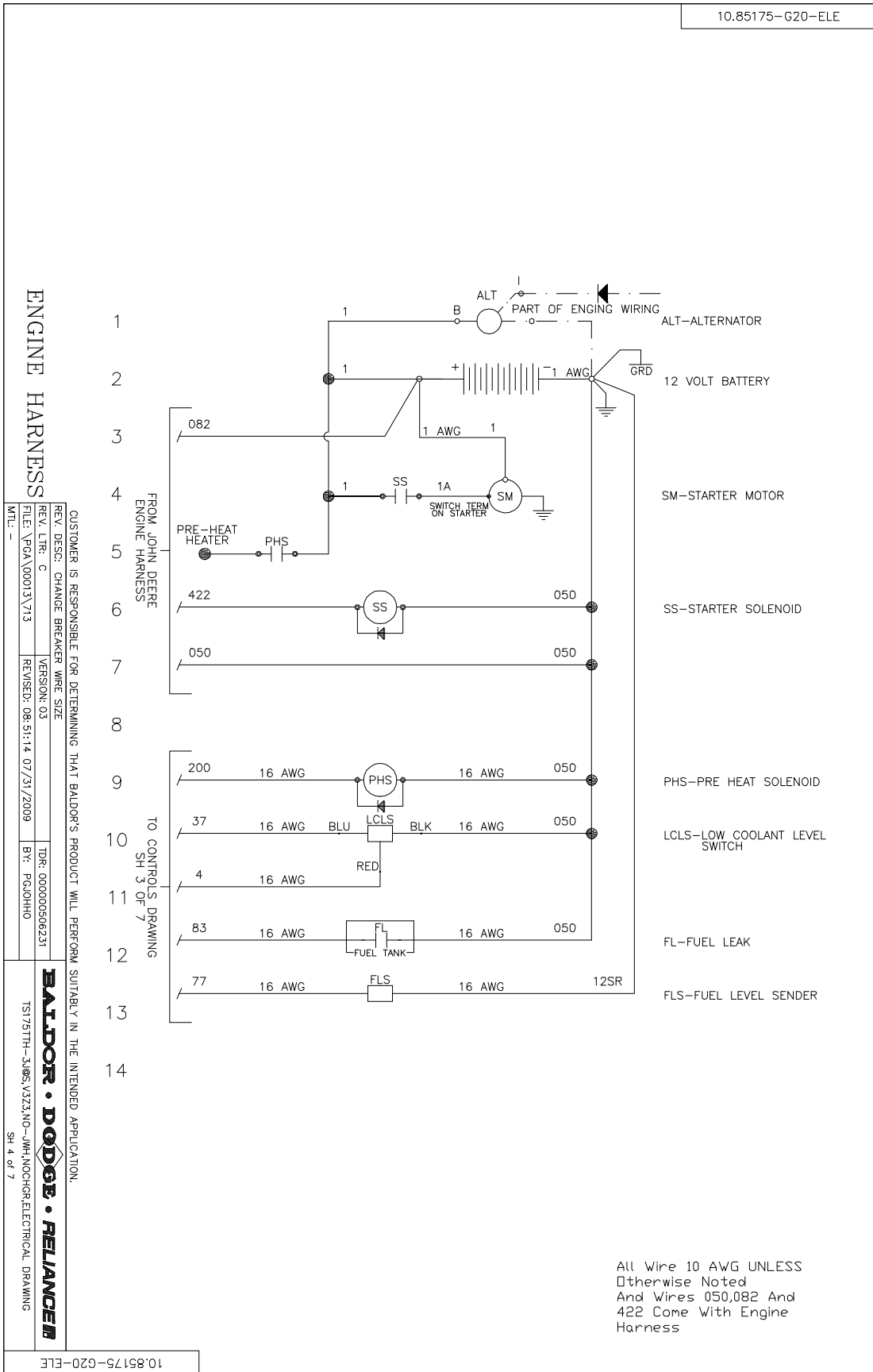

ENGINE HARNESS

CUSTOMER IS RESPONSIBLE FOR DETERMINING THAT BALDOR'S PRODUCT WILL PERFORM SUITABLY IN THE INTENDED APPLICATION.
 REV. DESC: CHANGE BREAKER WIRE SIZE
 REV. LTR: C
 VERSION: 03
 FILE: P0A\00013\713
 REVISED: 08/31/14 07/31/2009
 BR: PGIJHHO

BALDOR • DODGE • RELIANCE
 TS175TH-3J08; V323NO-JWH; NOCHRG; ELECTRICAL DRAWING
 SH 4 of 7

All Wire 10 AWG UNLESS
 Otherwise Noted
 And Wires 050,082 And
 422 Come With Engine
 Harness

10.85175-G20-ELE

Figure A-44 TS175

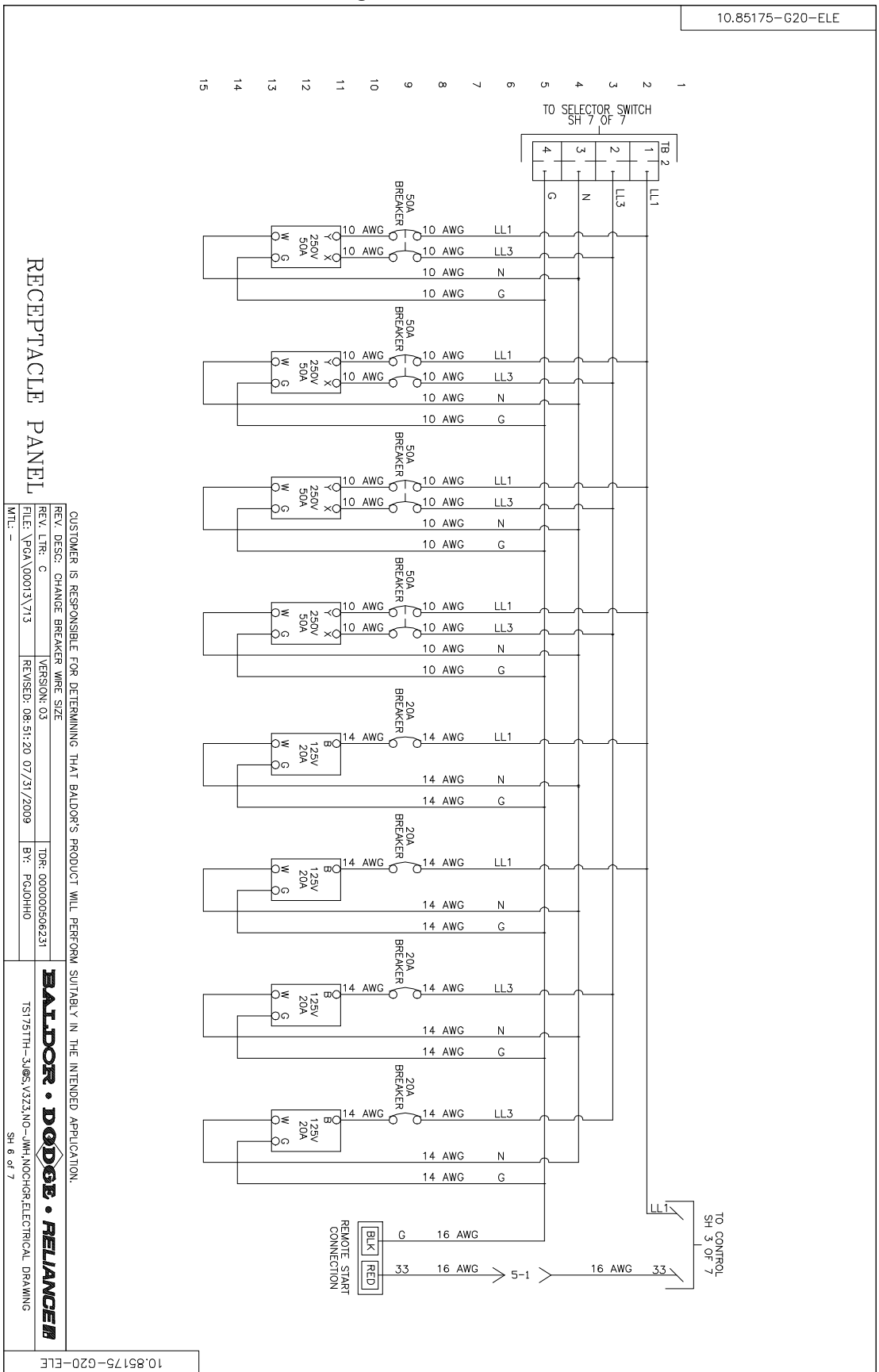

Figure A-45 TS175

10.85175-G20-ELE

CONNECTOR #2
12 PIN

PIN NUMBER	WIRE NUMBER
1	8A
2	11A
3	4F
4	21
5	11
6	77
7	201
8	33
9	37
10	85
11	83
12	-

CONNECTOR #4
6 PIN

PIN NUMBER	WIRE NUMBER
1	123R
2	77
3	200
4	37
5	4
6	83

CONNECTOR #5
6 PIN

PIN NUMBER	WIRE NUMBER
1	33
2	L1
3	G
4	N
5	L1
6	-

CONNECTOR #3
6 PIN

PIN NUMBER	WIRE NUMBER
1	1
2	4
3	12
4	CAN HIGH
5	CAN LDW
6	CAN CDM

CONNECTOR #1
15 PIN

PIN NUMBER	WIRE NUMBER
1	V1
2	V2
3	V3
4	N
5	C1
6	C2
7	C3
8	C0
9	-
10	-
11	-
12	LL1
13	62
14	63
15	-

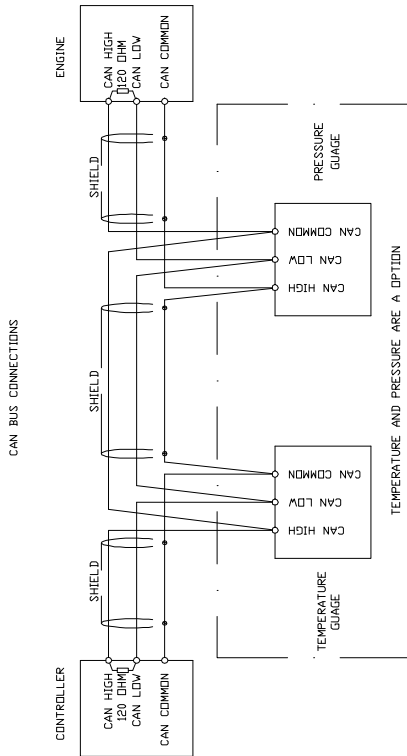

CAN BUS CABLES MUST BE CONNECTED IN SERIES, FROM ONE COMPONENT TO THE NEXT (NO STUBS, NO STARS, AND NO BRANCHES) BOTH ENDS REQUIRE A 120 OHM TERMINATING RESISTOR WHICH MAY BE INTERNAL TO THE ENDING DEVICE. DO NOT ADD RESISTORS UNLESS SHOWN ON DRAWING AS ILLUSTRATED ABOVE.

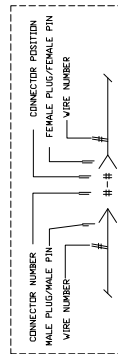

CUSTOMER IS RESPONSIBLE FOR DETERMINING THAT BALDOR'S PRODUCT WILL PERFORM SUITABLY IN THE INTENDED APPLICATION.

REV. DESC: CHANGE BREAKER WIRE SIZE	TDR: 000000506231
REV. LTR: C	VERSION: 03
FILE: \PGA\00013\713	REVISED: 08:51:15 07/31/2009
MTL: -	BY: PGJ0HHO

BALDOR • DODGE • RELIANCE

TS175TH-3J08S-V3Z3,NO-JWH,NOCHGR,ELECTRICAL DRAWING

SH 5 of 7

10.85175-G20-ELE

Figure A-46 TS250

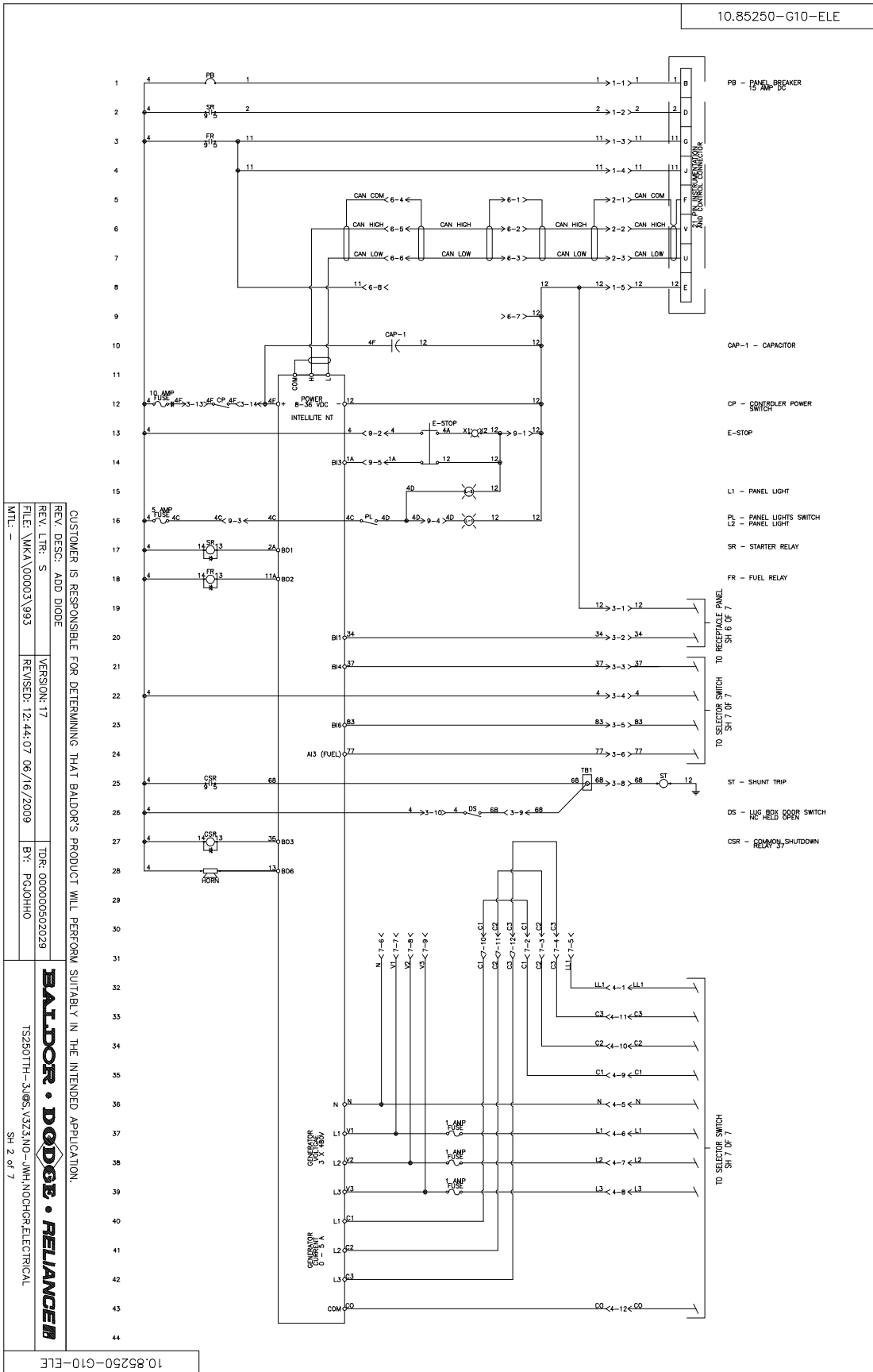

Figure A-47 TS250

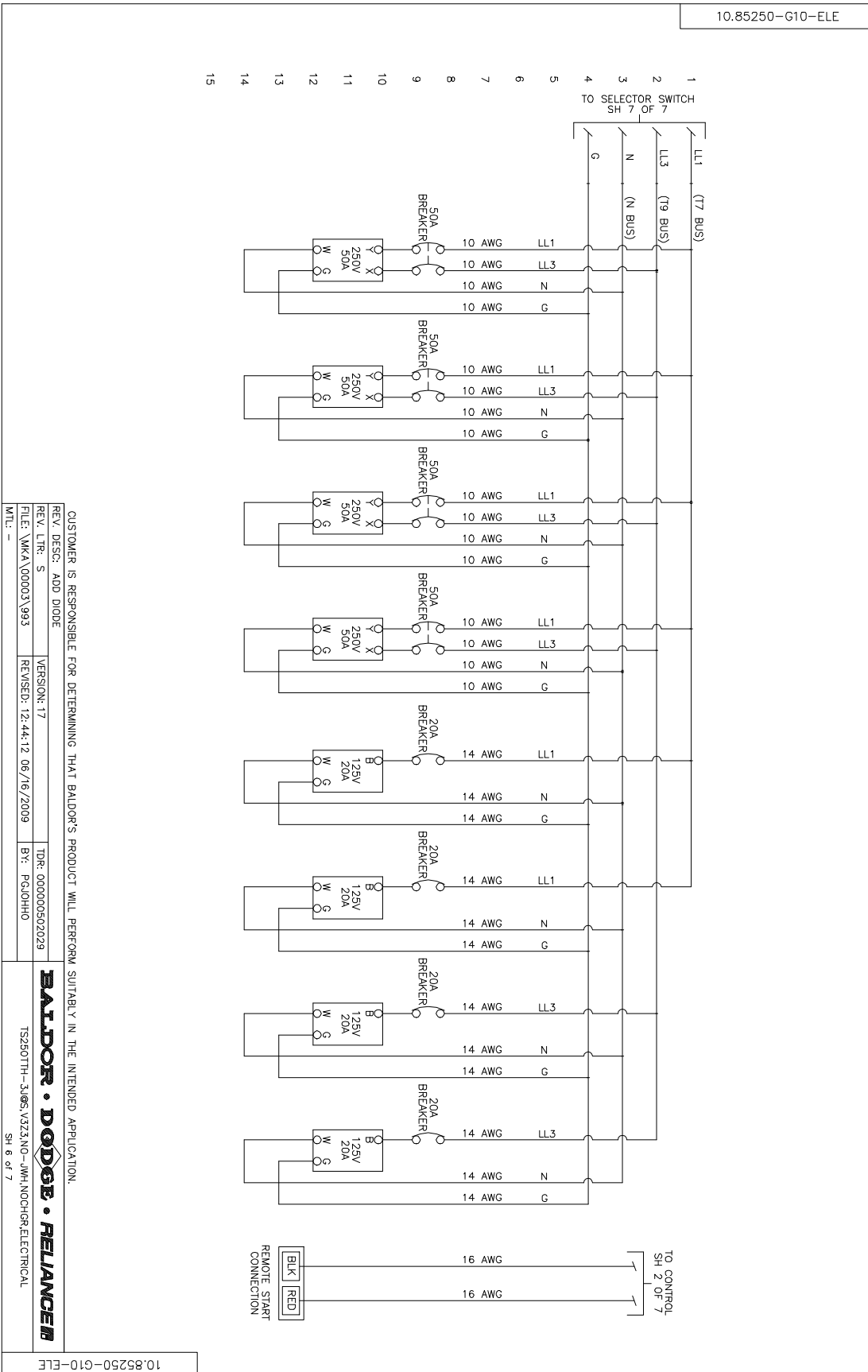

Figure A-48 TS250

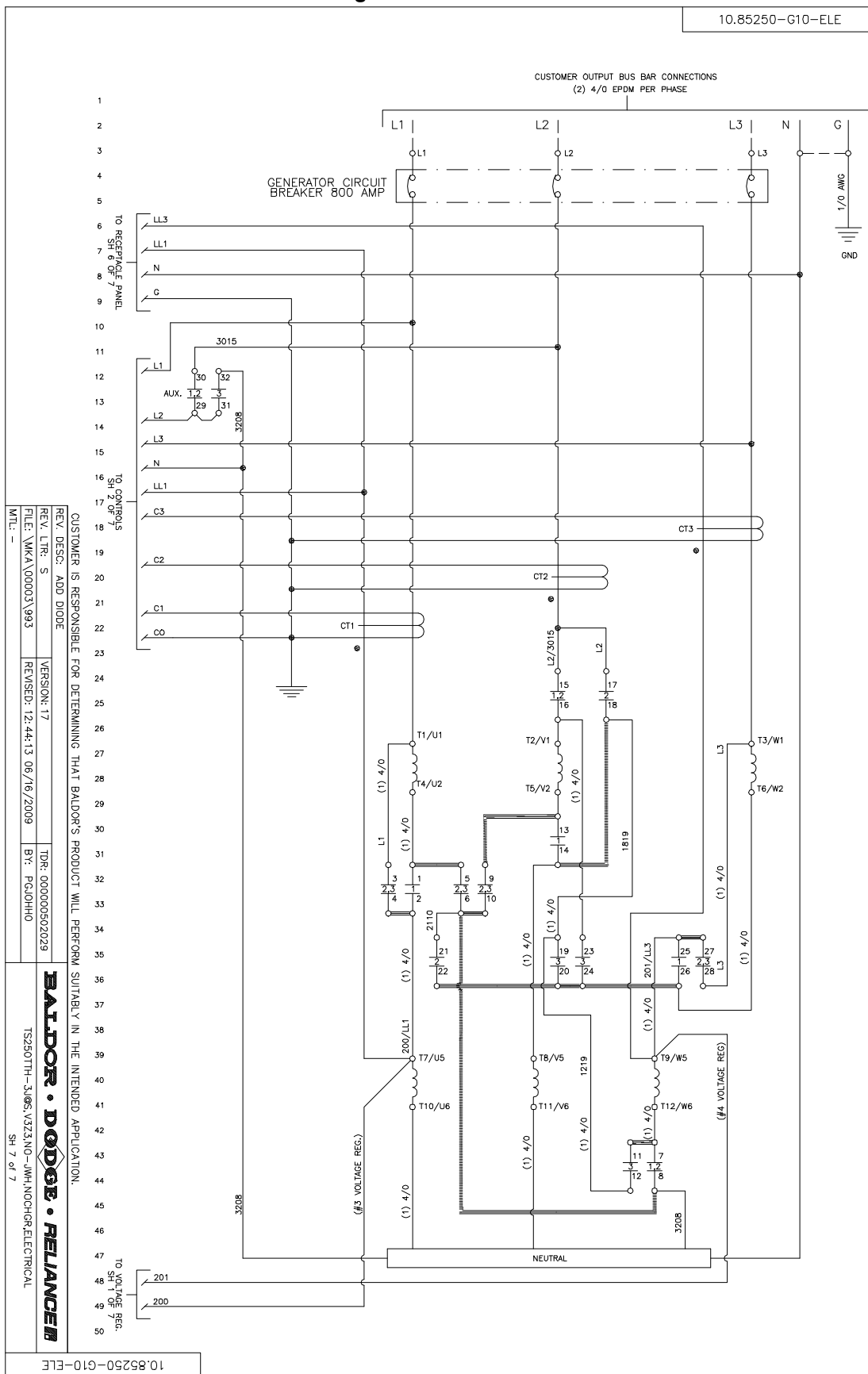

Figure A-49 TS250

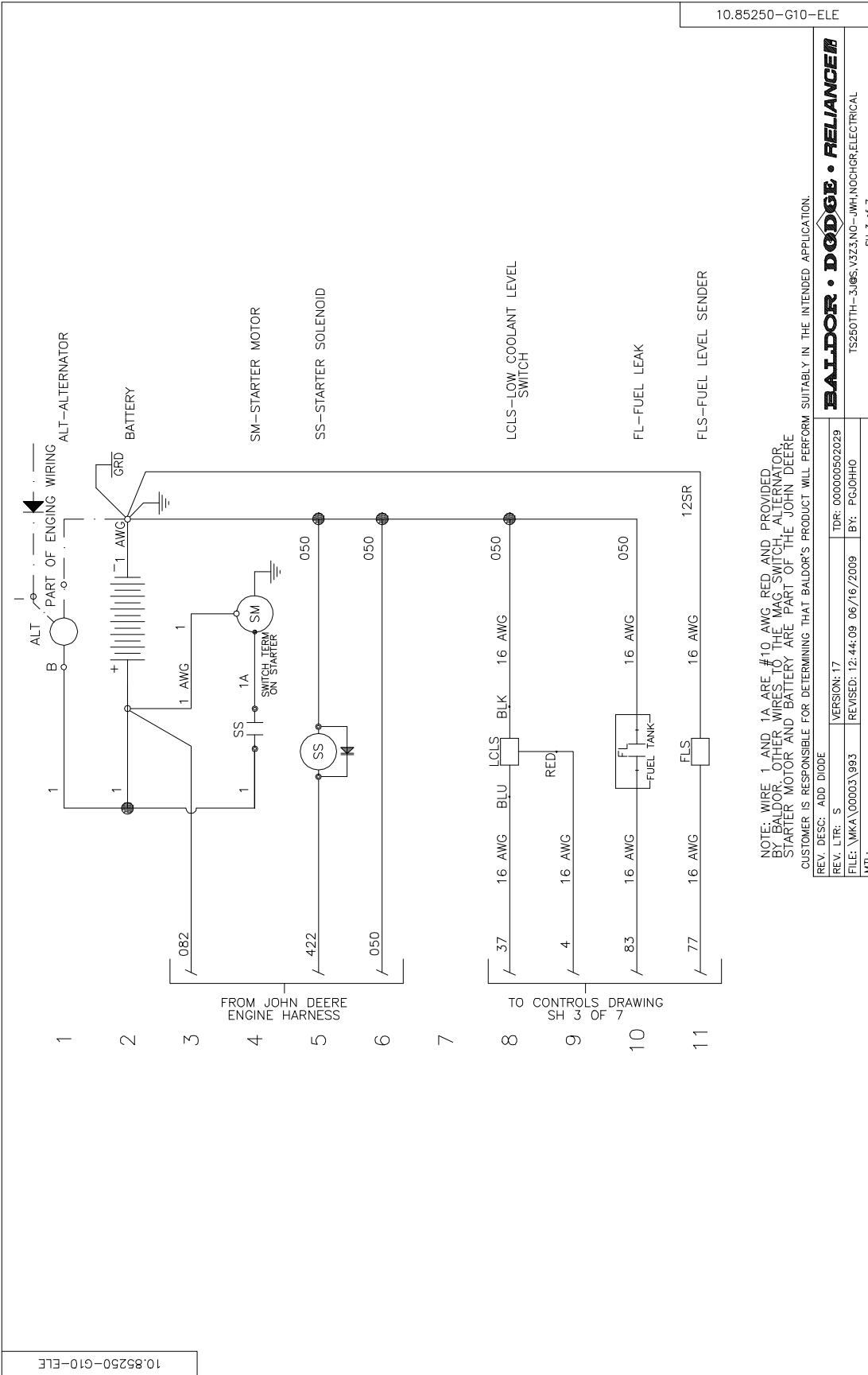

Figure A-50 TS250

10.85250-G10-ELE

CONNECTOR #1
6 PIN - ENGINE

PN NUMBER	WIRE NUMBER	NOTE
1	1	-
2	2	-
3	11	-
4	11	-
5	12	-
6	-	-

CONNECTOR #4
12 PIN - RECON SW TO PNL

PN NUMBER	WIRE NUMBER	NOTE
1	LU	-
2	-	-
3	-	-
4	-	-
5	N	-
6	L1	-
7	L2A	-
8	L3	-
9	C1	-
10	C2	-
11	C3	-
12	CO	-

CONNECTOR #7
12 PIN - ANALOG METERS

PN NUMBER	WIRE NUMBER	NOTE
1	CO	-
2	C1	-
3	C2	-
4	C3	-
5	L1	-
6	N	-
7	V1	-
8	V2	-
9	V3	-
10	C1	-
11	C2	-
12	C3	-

CONNECTOR #2
3 PIN - CAN

PN NUMBER	WIRE NUMBER	NOTE
1	CC	CAN COMMON (SHIELD)
2	CH	CAN HIGH
3	CL	CAN LOW

CONNECTOR #3
15 PIN - MISC.

PN NUMBER	WIRE NUMBER	NOTE
1	12	-
2	34	-
3	37	-
4	4	TO LCL
5	83	-
6	77	-
7	12SR	-
8	-	FROM DOOR SWITCH
9	68	TO DOOR SWITCH
10	4	TO DOOR SWITCH
11	62	-
12	63	-
13	-	-
14	-	-
15	-	-

CONNECTOR #6
9 PIN - ANALOG ENGINE GAUGES

PN NUMBER	WIRE NUMBER	NOTE
1	CC	CAN COMMON IN
2	CH	CAN HIGH IN
3	CL	CAN LOW IN
4	CC	CAN COMMON OUT
5	CH	CAN HIGH OUT
6	CL	CAN LOW OUT
7	12	-
8	11	-
9	-	-

CONNECTOR #9
9 PIN - E--STOP

PN NUMBER	WIRE NUMBER	NOTE
1	12	-
2	4	-
3	4C	-
4	4D	-
5	1A	-
6	62	-
7	63	-
8	-	-
9	-	-

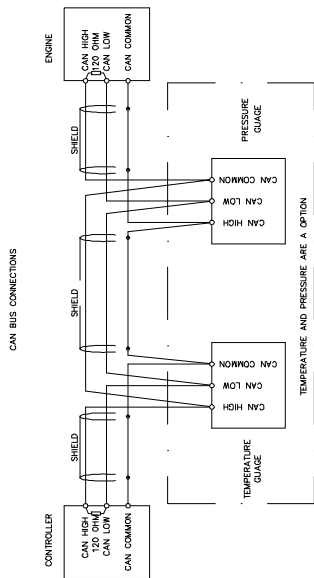

CAN BUS CABLES MUST BE CONNECTED IN SERIES FROM ONE COMPONENT TO THE NEXT (BUS TERMINUS AND STOPS). BUS BRANCHES (BOTH ENDS) REQUIRE A 120 OHM TERMINATING RESISTOR WHICH MAY BE INTERNAL TO THE ENGINE DEVICE (DO NOT ADD RESISTORS UNLESS SHOWN ON DRAWING AS ILLUSTRATED ABOVE).

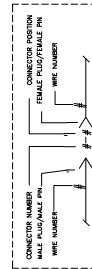

GENERAL INFORMATION

CUSTOMER IS RESPONSIBLE FOR DETERMINING THAT BALDOR'S PRODUCT WILL PERFORM SUITABLY IN THE INTENDED APPLICATION.

REV. DESC: ADD DODGE
REV. LTR: S
FILE: \MKA\00003\993

VERSION: 17
REVISED: 12/44/11 06/16/2009
BY: PGJOHHO

TDR: 00000502029

BALDOR • DODGE • RELIANCE

TS250TH-3J085-V3Z3.NO--JMH.NOCHGR.ELECTRICAL

SH 5 of 7

10.85250-G10-ELE

Figure A-51 TS250

10.85250-G10-ELE

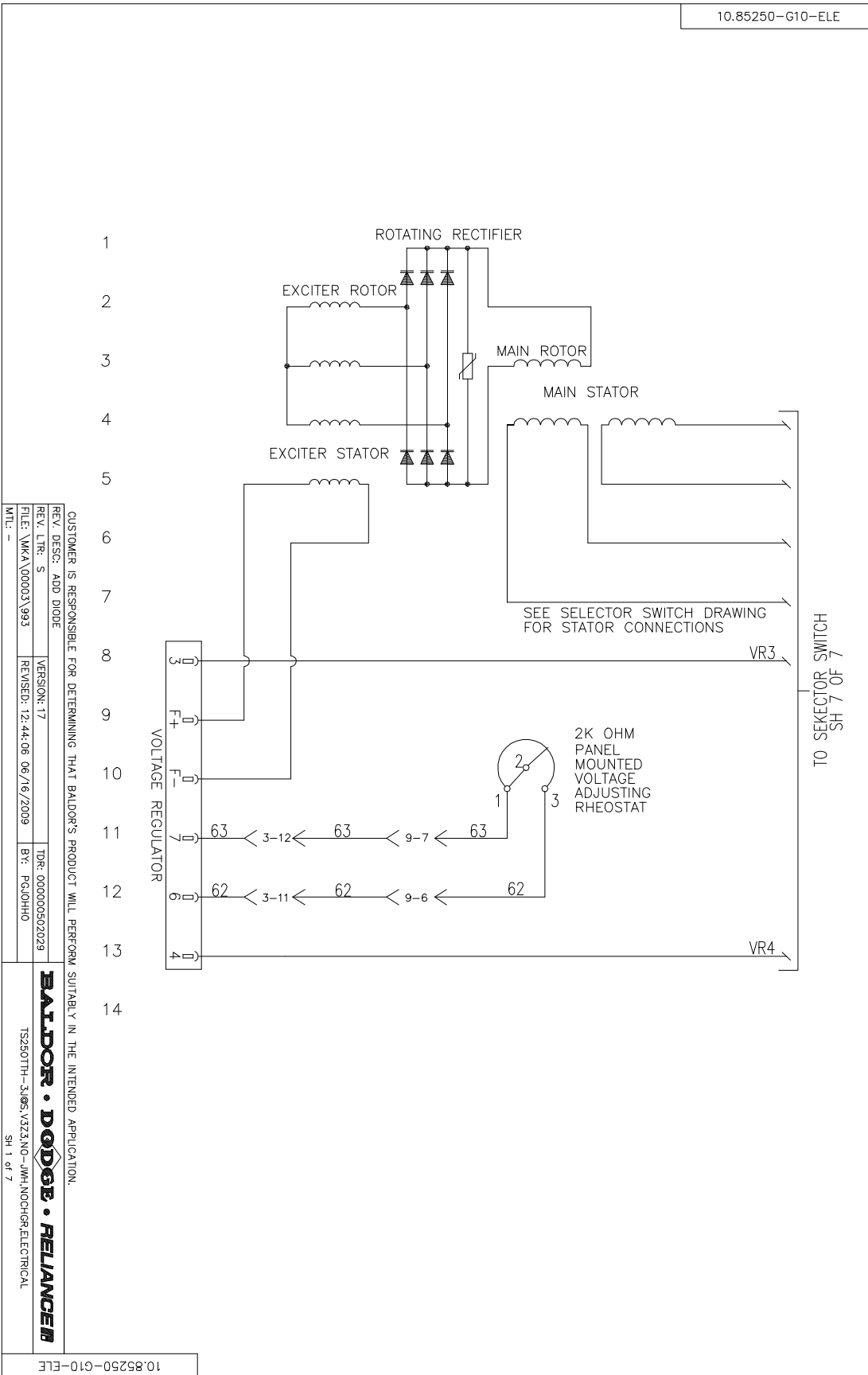

CUSTOMER IS RESPONSIBLE FOR DETERMINING THAT BALDOR'S PRODUCT WILL PERFORM SUITABLY IN THE INTENDED APPLICATION.

REV. DESC: ADD DIODE	VERSION: 17	TDR: 00000502029
REV. LTR: S	REVISED: 12-44:06 06/16/2009	BY: PGJ0HH0
FILE: \MKA\00003\993		
MTL: -		

BALDOR • DODGE • RELIANCE

TS250TTH-3J0S.V3Z3.NO-JWH.N0CHGR.ELECTRICAL

SH 1 of 7

10.85250-G10-ELE

Figure A-52 TS250

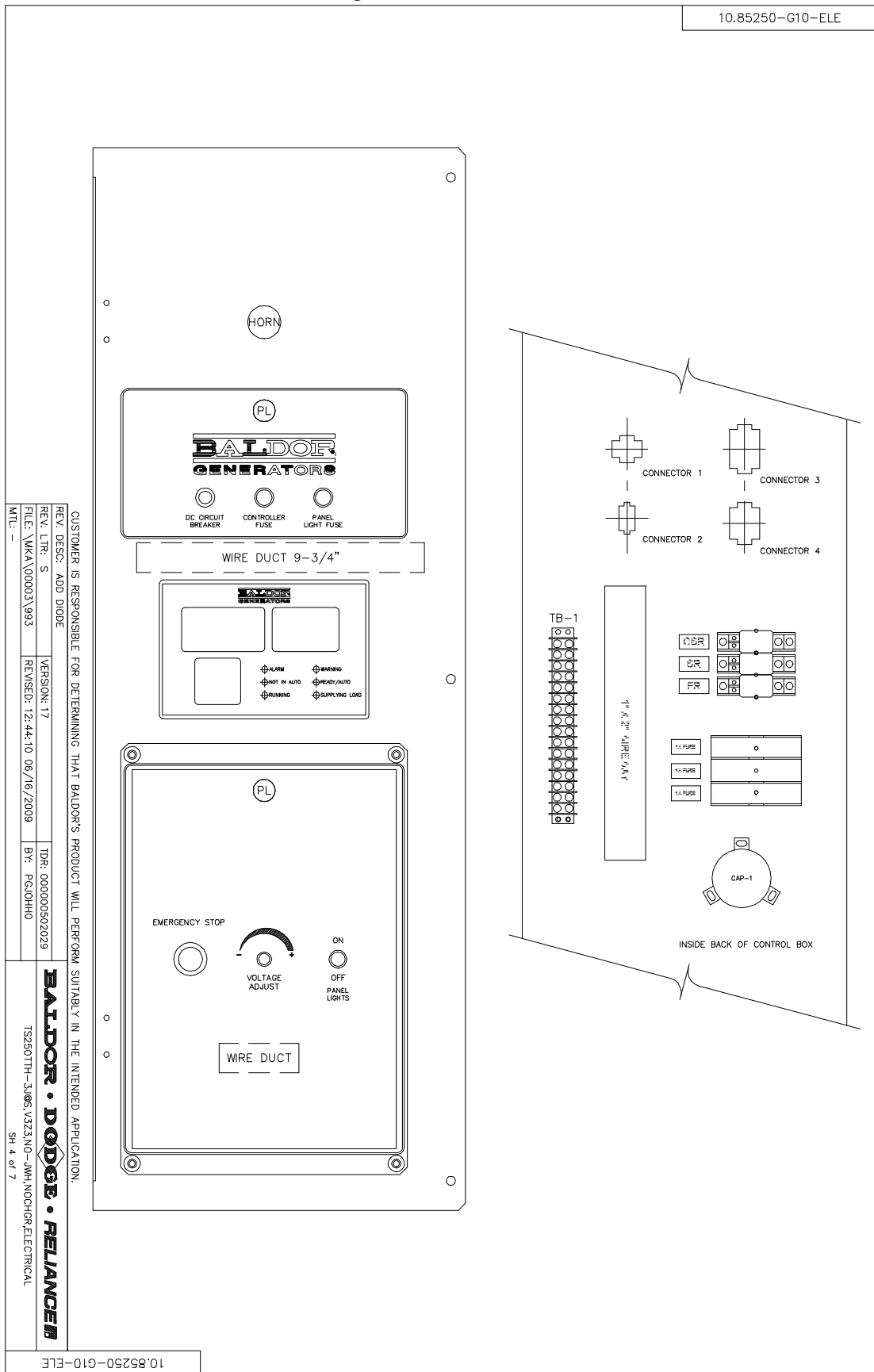

Figure A-53 TS350

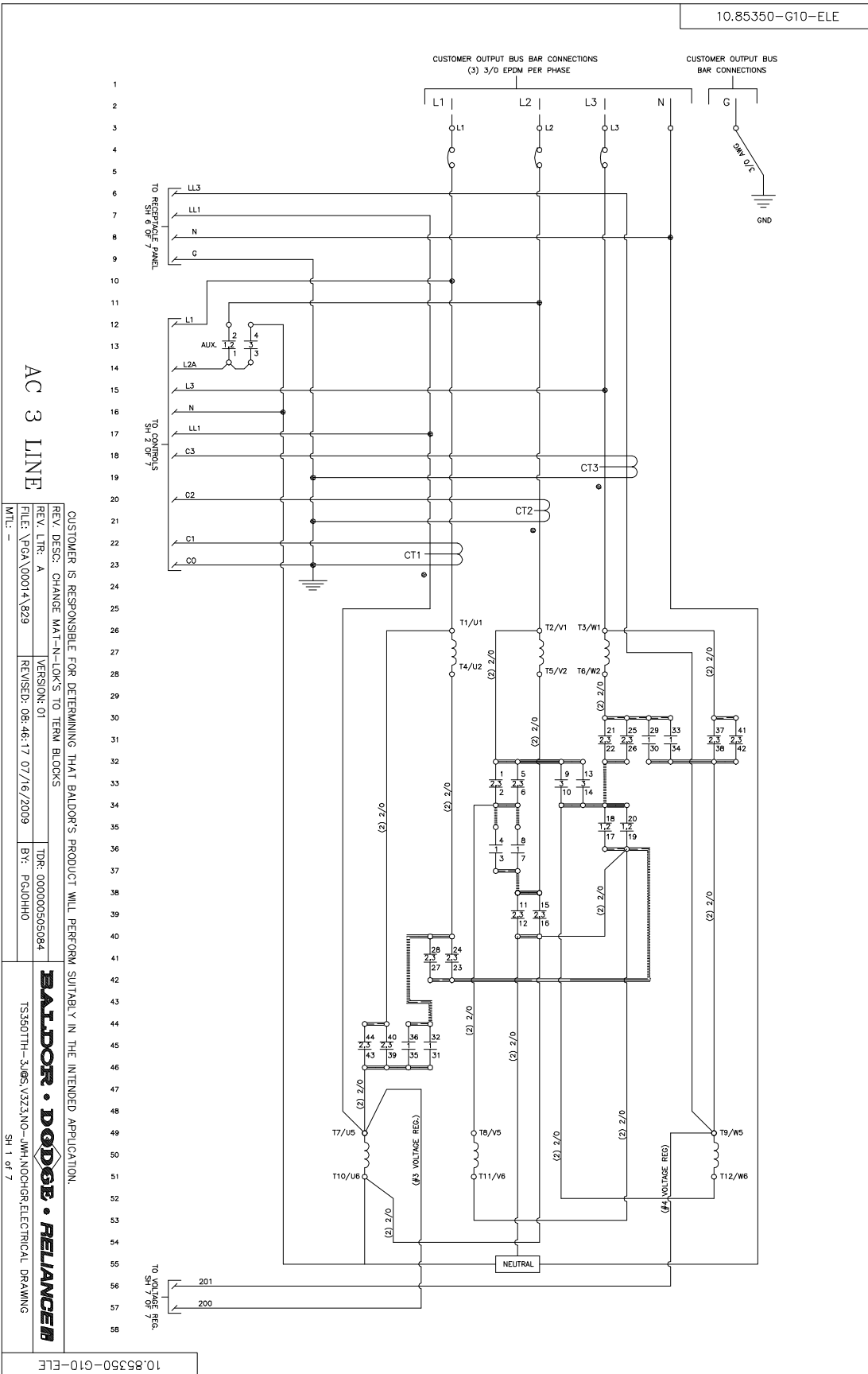

Figure A-54 TS350

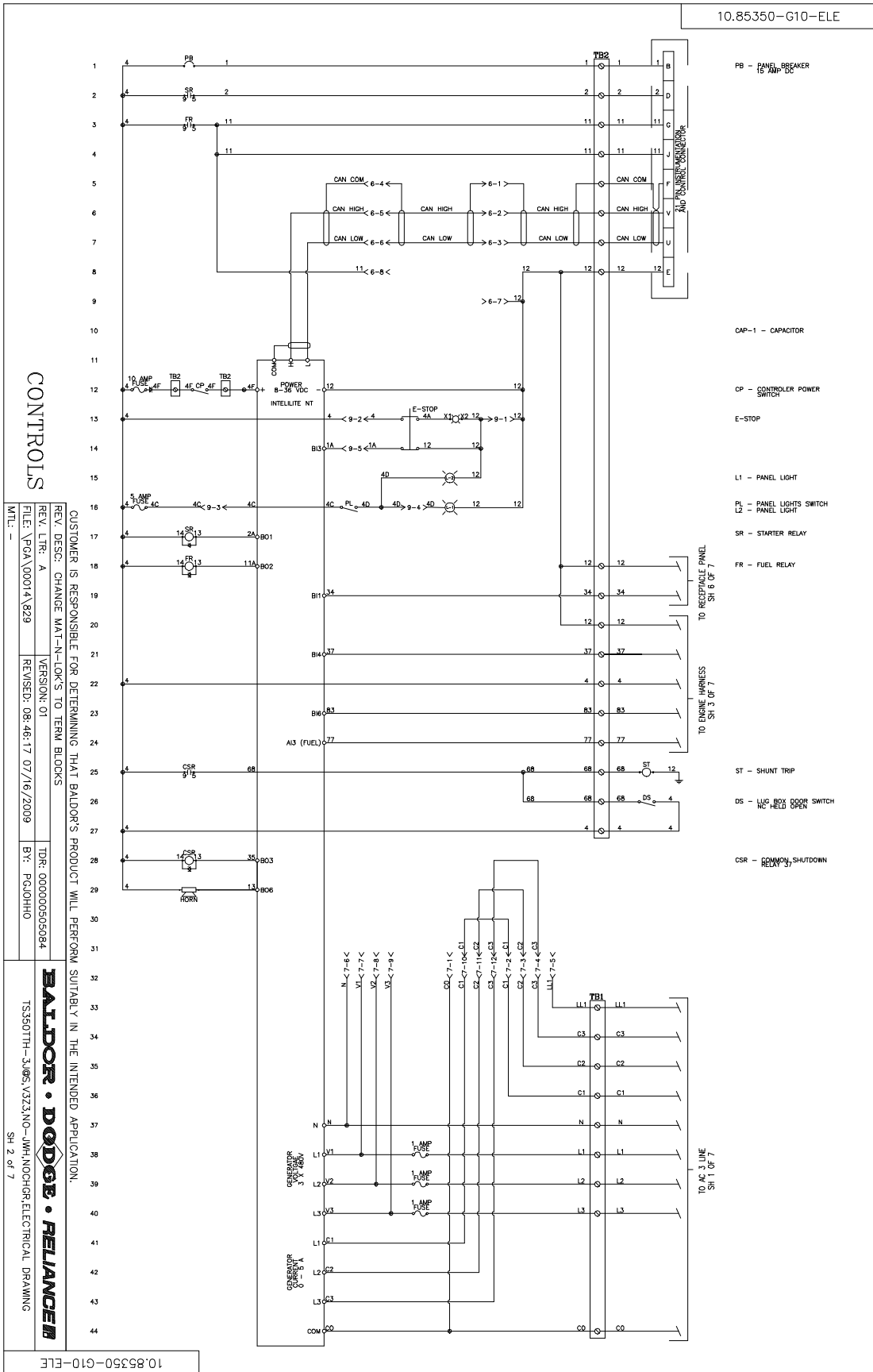
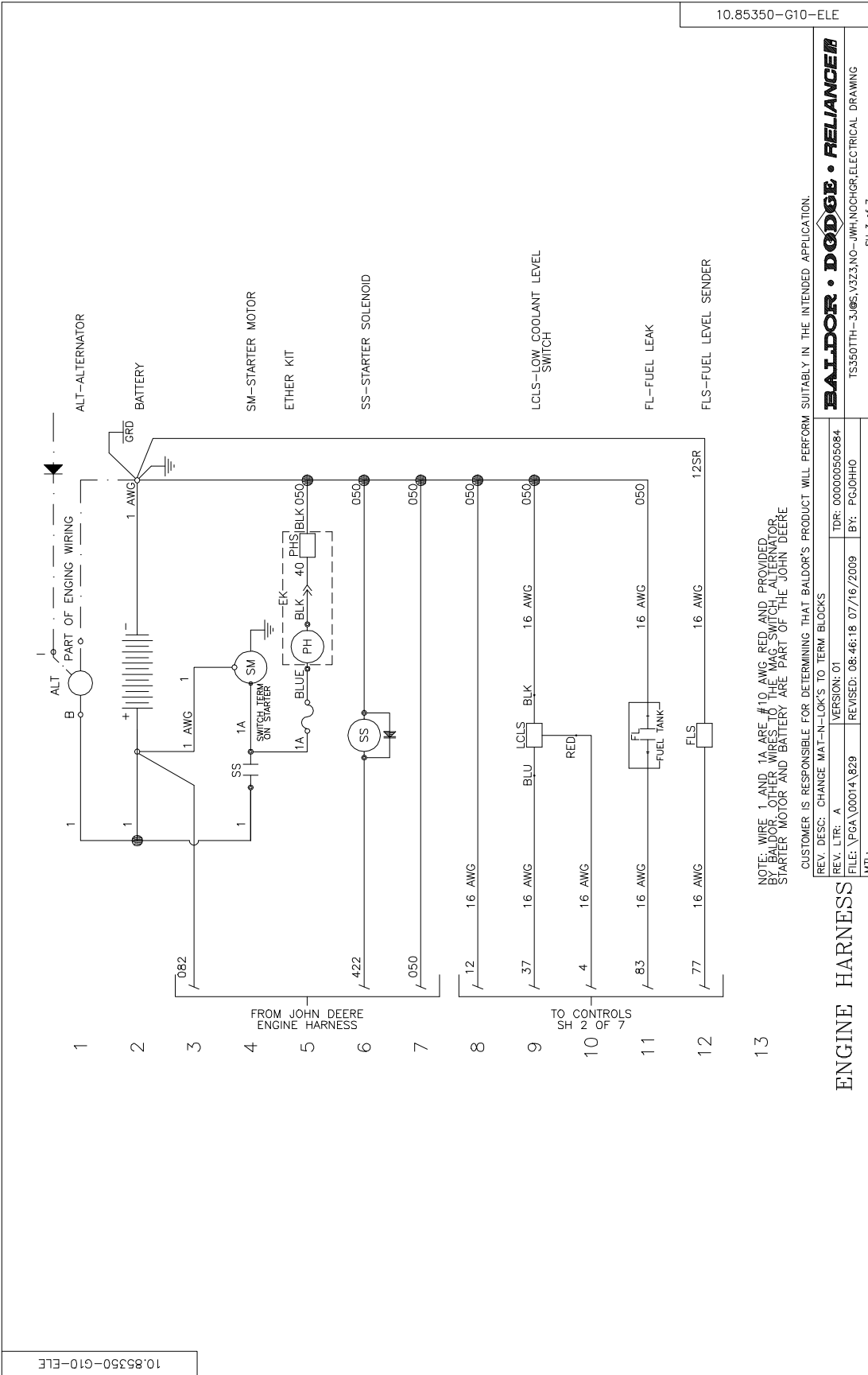

Figure A-55 TS350



10.85350-G10-ELE

NOTE: WIRE #1 AND 1A ARE #10 AWG RED AND PROVIDED BY BALDOR. OTHER WIRES TO THE MAG SWITCH, ALTERNATOR, STARTER MOTOR AND BATTERY ARE PART OF THE JOHN DEERE

CUSTOMER IS RESPONSIBLE FOR DETERMINING THAT BALDOR'S PRODUCT WILL PERFORM SUITABLY IN THE INTENDED APPLICATION.

REV. DESC: CHANGE MAT-N-LOK'S TO TERM BLOCKS
 REV. LTR: A
 FILE: \P6A\00014\829
 MTL: -

VERSION: 01
 TDR: 000000505084
 REVISION: 01
 REVISION: 08-46-18 07/16/2009
 BY: PGJ0HHO

ENGINE HARNESS

TS350THH-3.06S.V323.NO-JWH.NOCHEGE.ELECTRICAL DRAWING
 SH 3 of 7

BALDOR • DODGE • RELIANCE

Figure A-56 TS350

10.85350-G10-ELE

CONNECTOR #6
9 PIN - ANALOG ENGINE GAUGES

PIN NUMBER	WIRE NUMBER	NOTE
1	OC	CAN COMMON IN
2	OH	CAN HIGH IN
3	OL	CAN LOW IN
4	OC	CAN COMMON OUT
5	OH	CAN HIGH OUT
6	OL	CAN LOW OUT
7	12	-
8	11	-
9	-	-

CONNECTOR #7
12 PIN - DIGITAL PANEL

PIN NUMBER	WIRE NUMBER	NOTE
1	-	-
2	C1	-
3	C2	-
4	C3	-
5	-	-
6	-	-
7	-	-
8	-	-
9	-	-
10	C1	-
11	C2	-
12	C3	-

CONNECTOR #9
9 PIN - E-STOP

PIN NUMBER	WIRE NUMBER	NOTE
1	12	-
2	4	-
3	4C	-
4	4D	-
5	1A	-
6	62	-
7	63	-
8	-	-
9	-	-

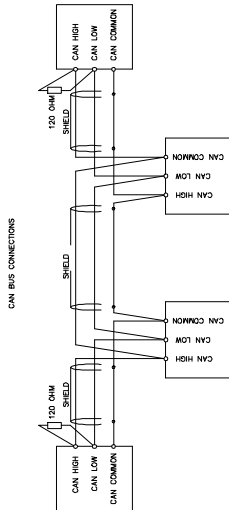

CAN BUS CABLES MUST BE CONNECTED IN SERIES, FROM ONE COMPONENT TO THE NEXT (NO STUBS, NO STARS, AND NO BRANCHES) TO THE NEXT. THE CAN BUS CABLES MUST BE CONNECTED TO THE CAN BUS TERMINATOR WHICH MAY BE INTERNAL TO THE ENDING DEVICE. DO NOT ADD RESISTORS UNLESS SHOWN ON DRAWING OR ILLUSTRATED ABOVE.

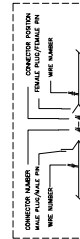

GENERAL INFORMATION

CUSTOMER IS RESPONSIBLE FOR DETERMINING THAT BALDOR'S PRODUCT WILL PERFORM SUITABLY IN THE INTENDED APPLICATION.

REV. DESC: CHANGE MAT-N-LOW'S TO TERM BLOCKS
 REV. LTR: A
 FILE: \VGA\00014\829
 MTL: -

VERSION: 01
 TDR: 00000505084
 BY: PGJOHNO

TS350TH-3, J86, V323, NO-JWH, NOCHGR, ELECTRICAL DRAWING
 SH 5 of 7

BALDOR • DODGE • RELIANCE

10.85350-G10-ELE

Figure A-57 TS350

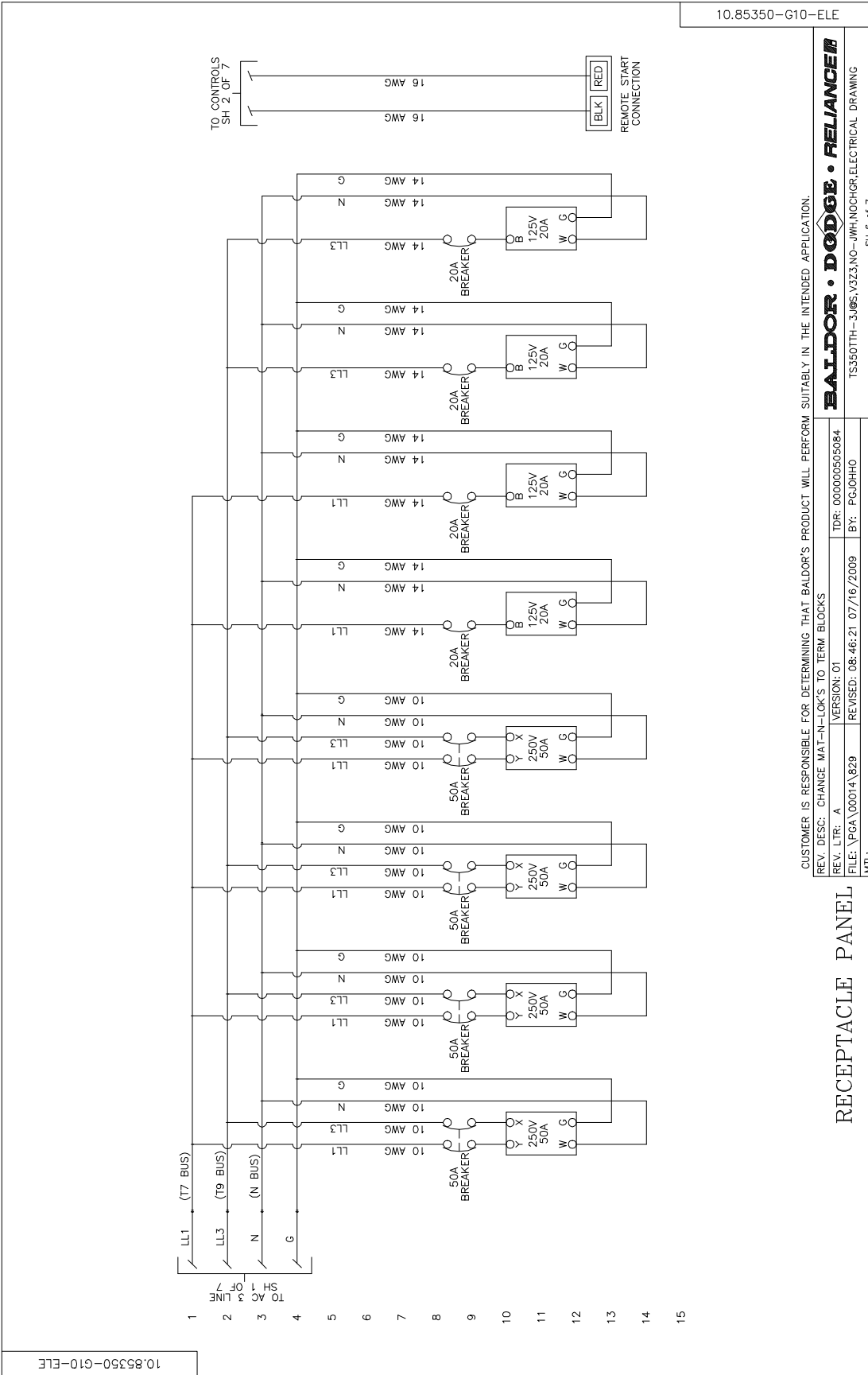

10.85350-G10-ELE

CUSTOMER IS RESPONSIBLE FOR DETERMINING THAT BALDOR'S PRODUCT WILL PERFORM SUITABLY IN THE INTENDED APPLICATION.

BALDOR • DODGE • RELIANCE
 TS350THH-3.00S.V323.NO-JWH.NOCHEGE.ELECTRICAL DRAWING
 SH 6 of 7

RECEPTACLE PANEL

Figure A-59 TS400 Connection Diagram

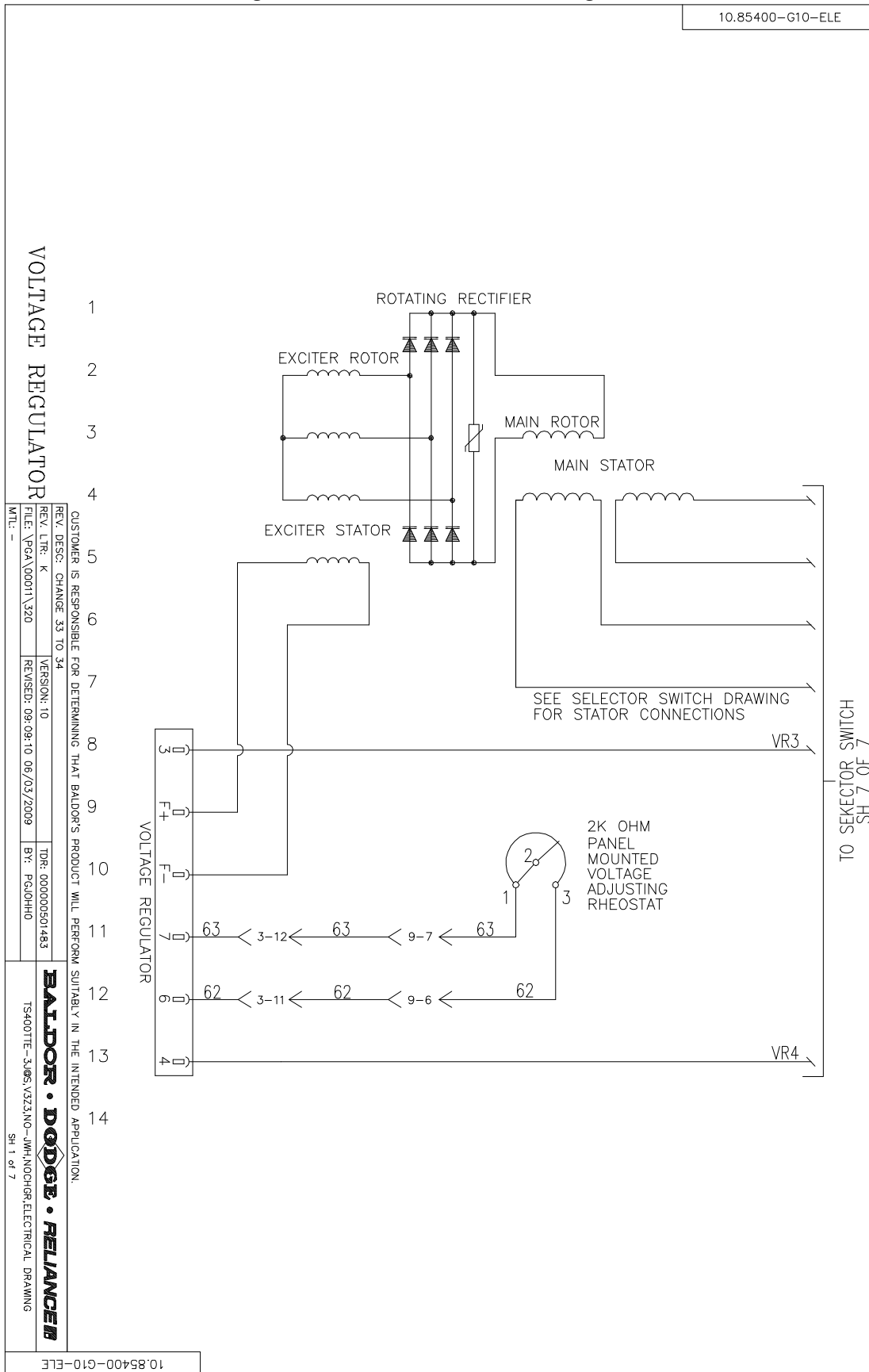
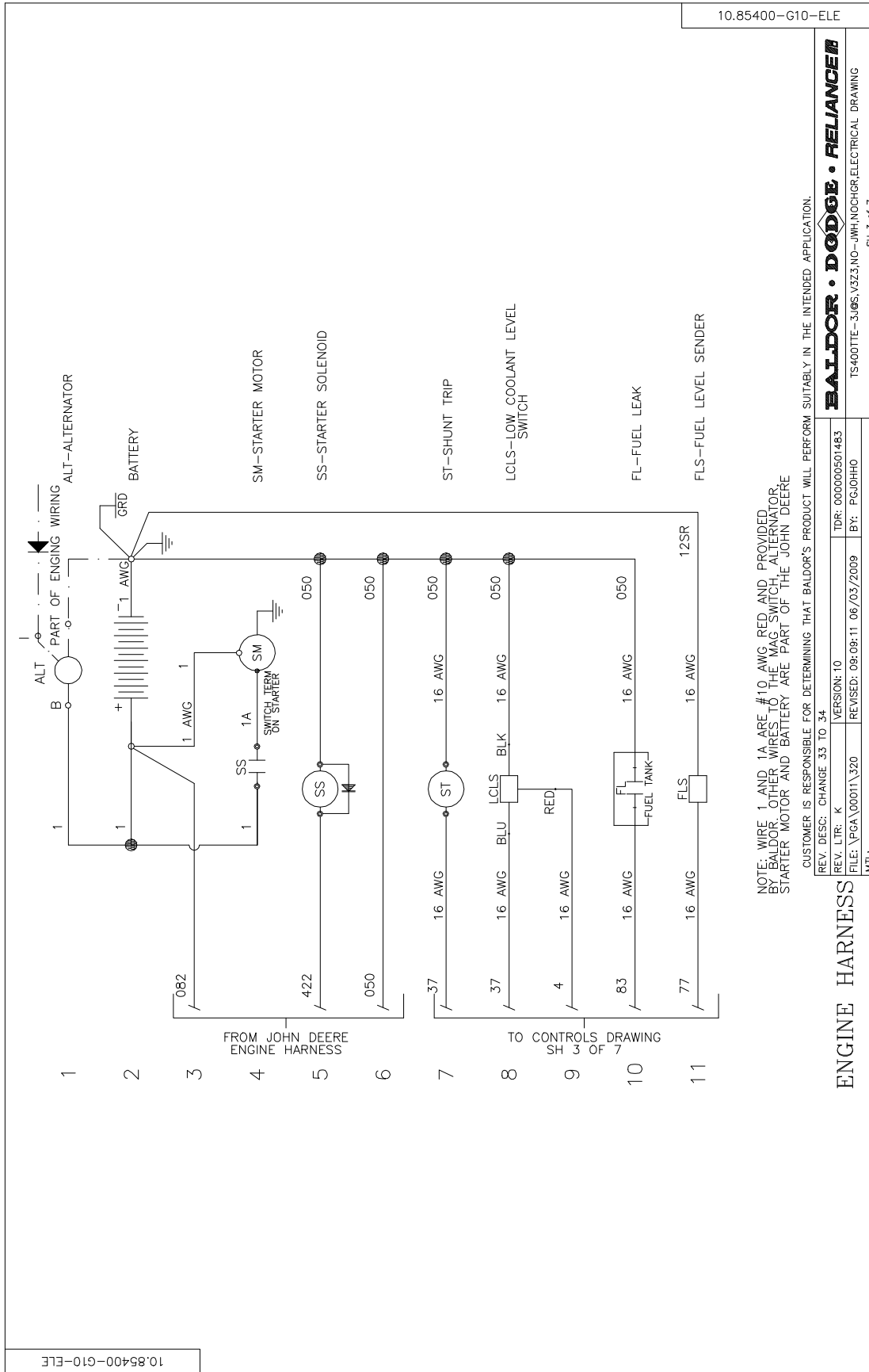

Figure A-61 TS400 Connection Diagram



10.85400-G10-ELE

10.85400-G10-ELE

NOTE: WIRE 1 AND 1A ARE #10 AWG RED AND PROVIDED BY BALDOR. OTHER WIRES TO THE MAG SWITCH, ALTERNATOR, STARTER MOTOR AND BATTERY ARE PART OF THE JOHN DEERE

CUSTOMER IS RESPONSIBLE FOR DETERMINING THAT BALDOR'S PRODUCT WILL PERFORM SUITABLY IN THE INTENDED APPLICATION.

BALDOR • DODGE • RELIANCE
 TS400TTE-3.06S.V323.NO-JWH.NOCHGR.ELECTRICAL DRAWING
 SH 3 of 7

REV. DESC: CHANGE 33 TO 34	VERSION: 10
REV. LTR: K	TDR: 00000501483
FILE: \PGA\00011\320	REVISED: 08/09/11 06/03/2009
MTL: -	BY: PGJOHHO

ENGINE HARNESS

Figure A-62 TS400 Connection Diagram

10.85400-G10-ELE

CONNECTOR #1
6 PIN - ENGINE

PIN NUMBER	WIRE NUMBER	NOTE
1	1	-
2	2	-
3	11	-
4	11	-
5	12	-
6	-	-

CAN BUS CONNECTIONS

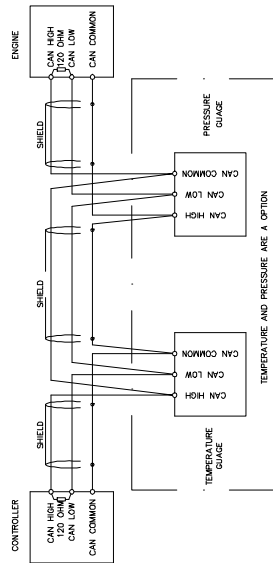

CAN BUS CABLES MUST BE CONNECTED IN SERIES FROM ONE COMPONENT TO THE NEXT (NO STUBS, NO STARS, AND NO BRANCHES) BOTH ENDS REQUIRE A 120 OHM TERMINATING RESISTOR WHICH MAY BE INTERNAL TO THE ENDING DEVICE, DO NOT ADD RESISTORS UNLESS SHOWN ON DRAWING AS ILLUSTRATED ABOVE.

CONNECTOR #4
12 PIN - RECON SW TO PNL

PIN NUMBER	WIRE NUMBER	NOTE
1	L1	-
2	-	-
3	-	-
4	-	-
5	N	-
6	L1	-
7	L2A	-
8	L3	-
9	C1	-
10	C2	-
11	C3	-
12	C0	-

CONNECTOR #7
12 PIN - ANALOG METERS

PIN NUMBER	WIRE NUMBER	NOTE
1	C0	-
2	C1	-
3	C2	-
4	C3	-
5	L1	-
6	N	-
7	V1	-
8	V2	-
9	V3	-
10	C1	-
11	C2	-
12	C3	-

CONNECTOR #2
3 PIN - CAN

PIN NUMBER	WIRE NUMBER	NOTE
1	CC	CAN COMMON (SHIELD)
2	CH	CAN HIGH
3	CL	CAN LOW

CONNECTOR #3
15 PIN - MISC.

PIN NUMBER	WIRE NUMBER	NOTE
1	12	-
2	34	-
3	37	-
4	4	TO LCL
5	83	-
6	77	-
7	12SR	-
8	-	-
9	68	FROM DOOR SWITCH
10	4	TO DOOR SWITCH
11	62	-
12	63	-
13	-	-
14	-	-
15	-	-

CONNECTOR #6
9 PIN - ANALOG ENGINE GAUGES

PIN NUMBER	WIRE NUMBER	NOTE
1	CC	CAN COMMON IN
2	CH	CAN HIGH IN
3	CL	CAN LOW IN
4	CC	CAN COMMON OUT
5	CH	CAN HIGH OUT
6	CL	CAN LOW OUT
7	12	-
8	11	-
9	-	-

CONNECTOR #9
9 PIN - E-STOP

PIN NUMBER	WIRE NUMBER	NOTE
1	12	-
2	4	-
3	4C	-
4	4D	-
5	1A	-
6	62	-
7	63	-
8	-	-
9	-	-



GENERAL INFORMATION

CUSTOMER IS RESPONSIBLE FOR DETERMINING THAT BALDOR'S PRODUCT WILL PERFORM SUITABLY IN THE INTENDED APPLICATION.

REV. DESC: CHANGE 33 TO 34	TDR: 00000501483
REV. LTR: K	BY: PGJOHHO
FILE: \PGA\00011\320	REVISED: 09:09:12 06/03/2009
MTL: -	

BALDOR • DODGE • RELIANCE
TS400ITE-3J085.V3Z3.NO-JWH.NDCHGR.ELECTRICAL DRAWING

SH 5 of 7

10.85400-G10-ELE

Figure A-63 TS400 Connection Diagram

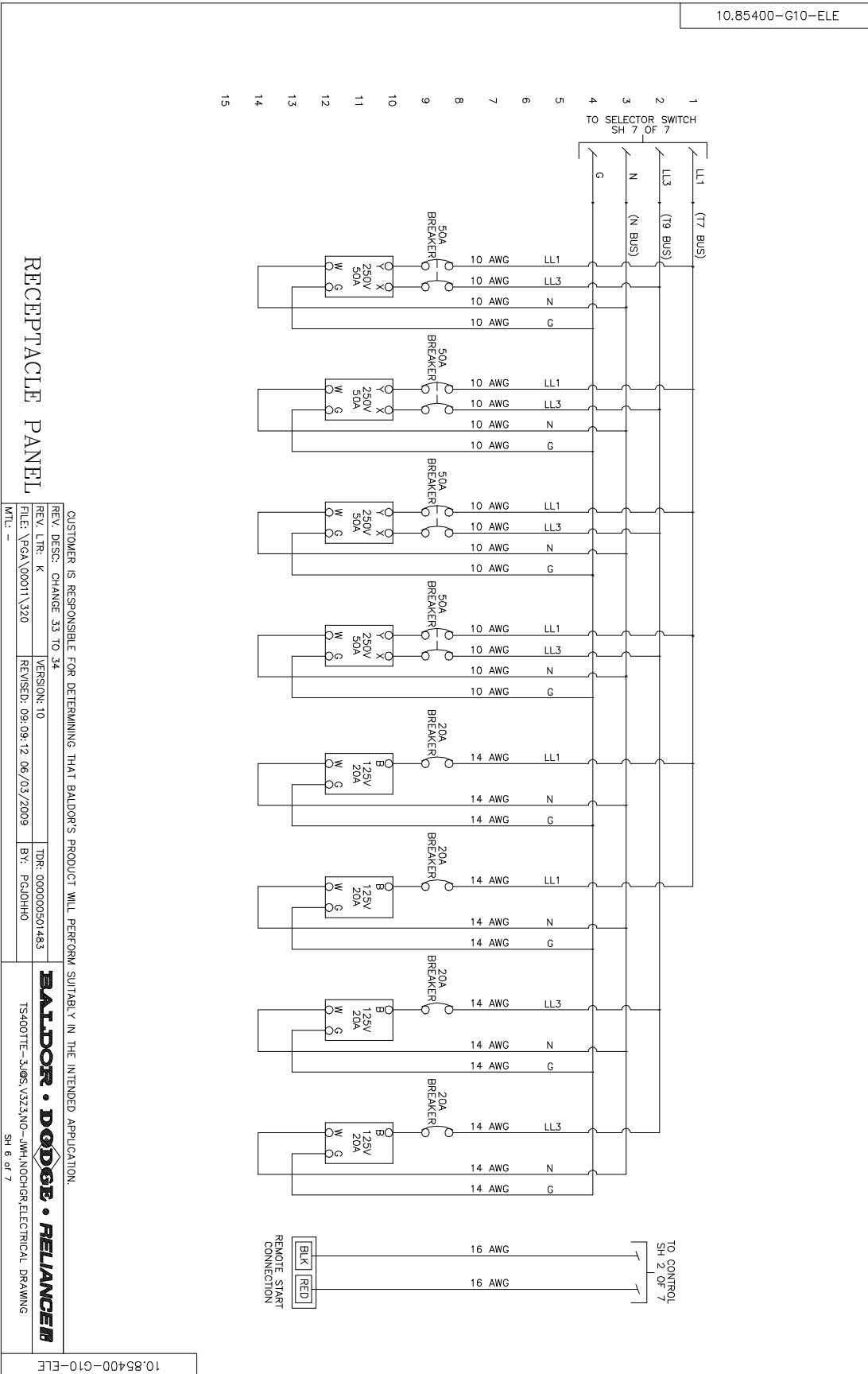

Figure A-64 TS400 Connection Diagram

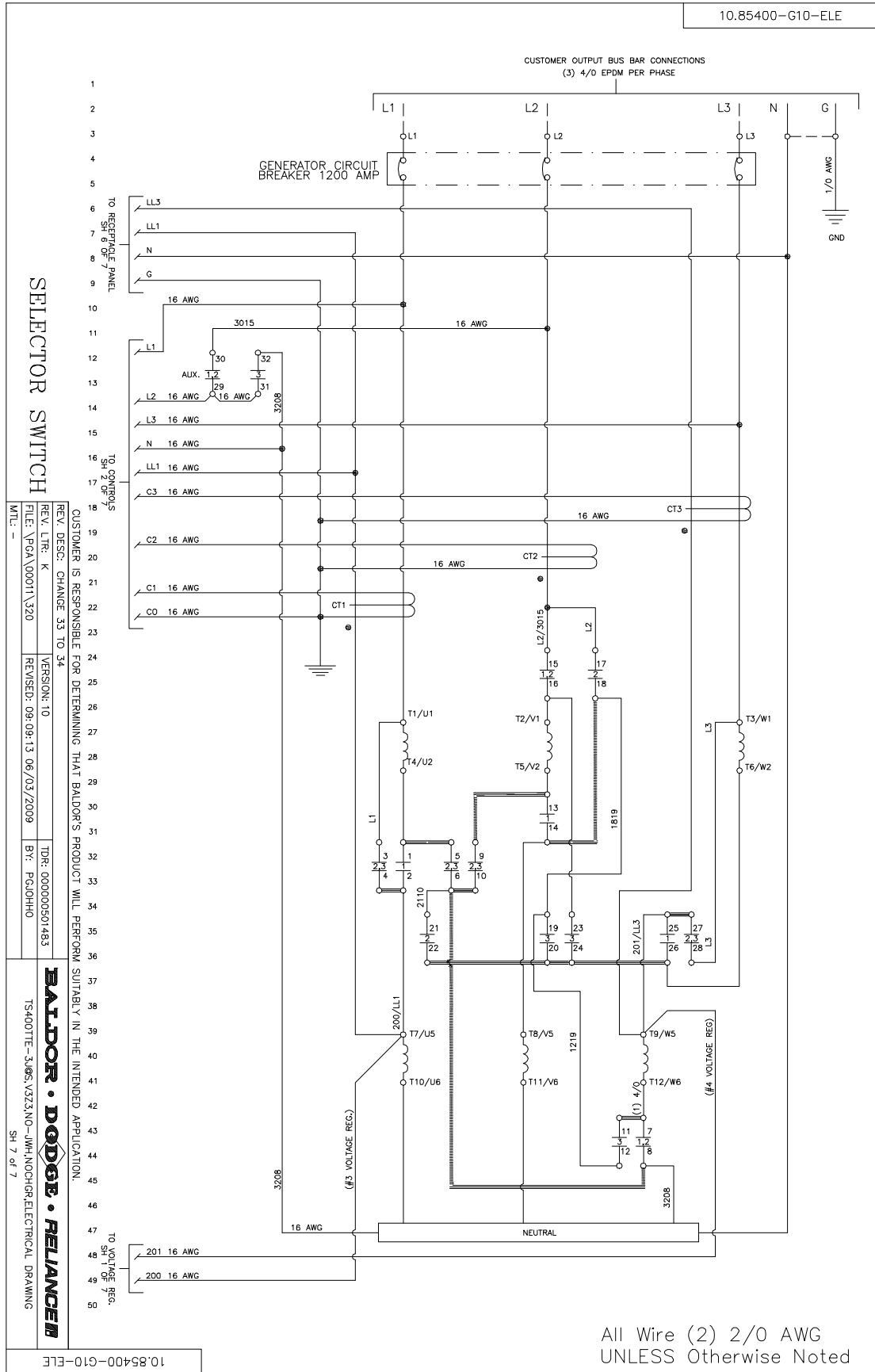

Figure A-65 TS500

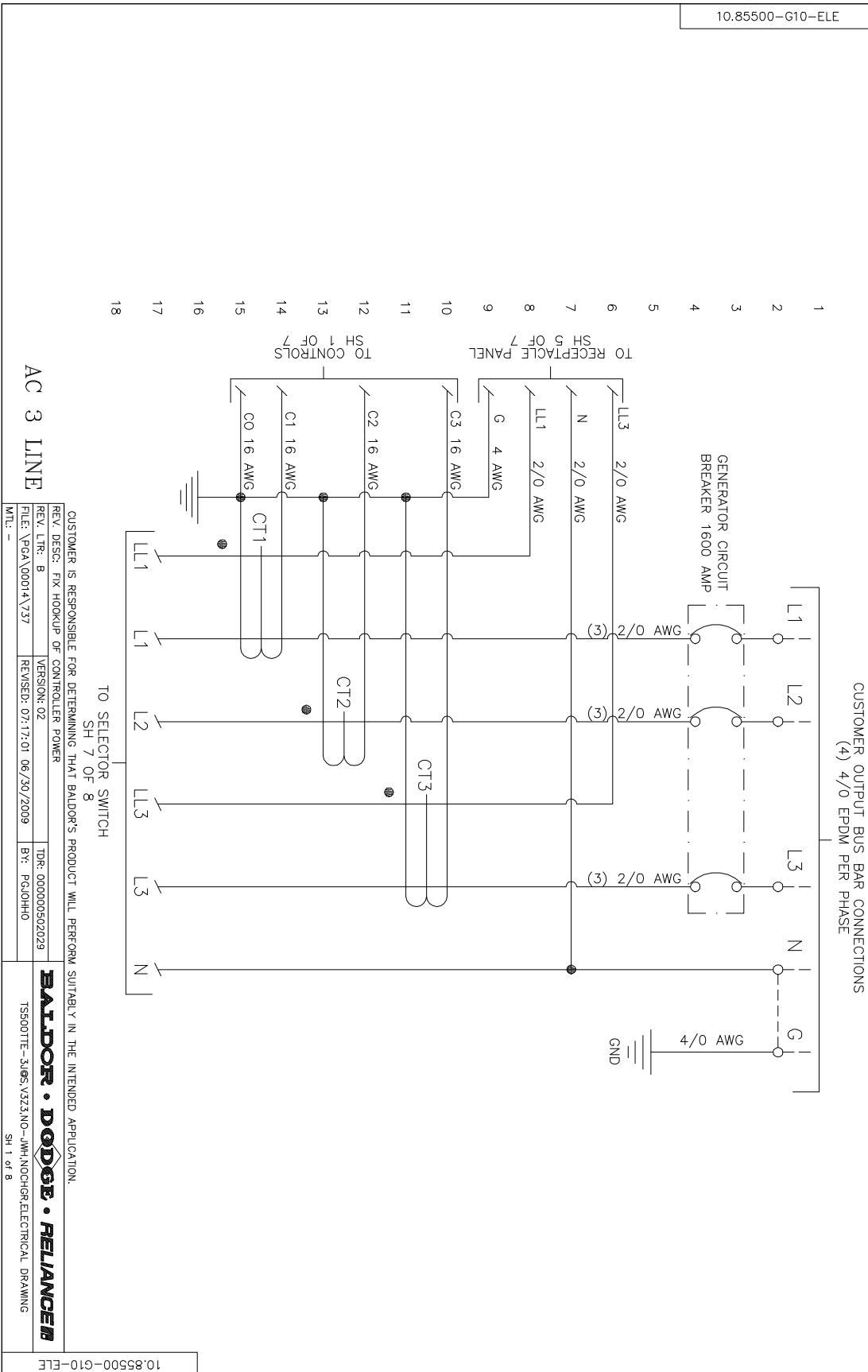

Figure A-66 TS500

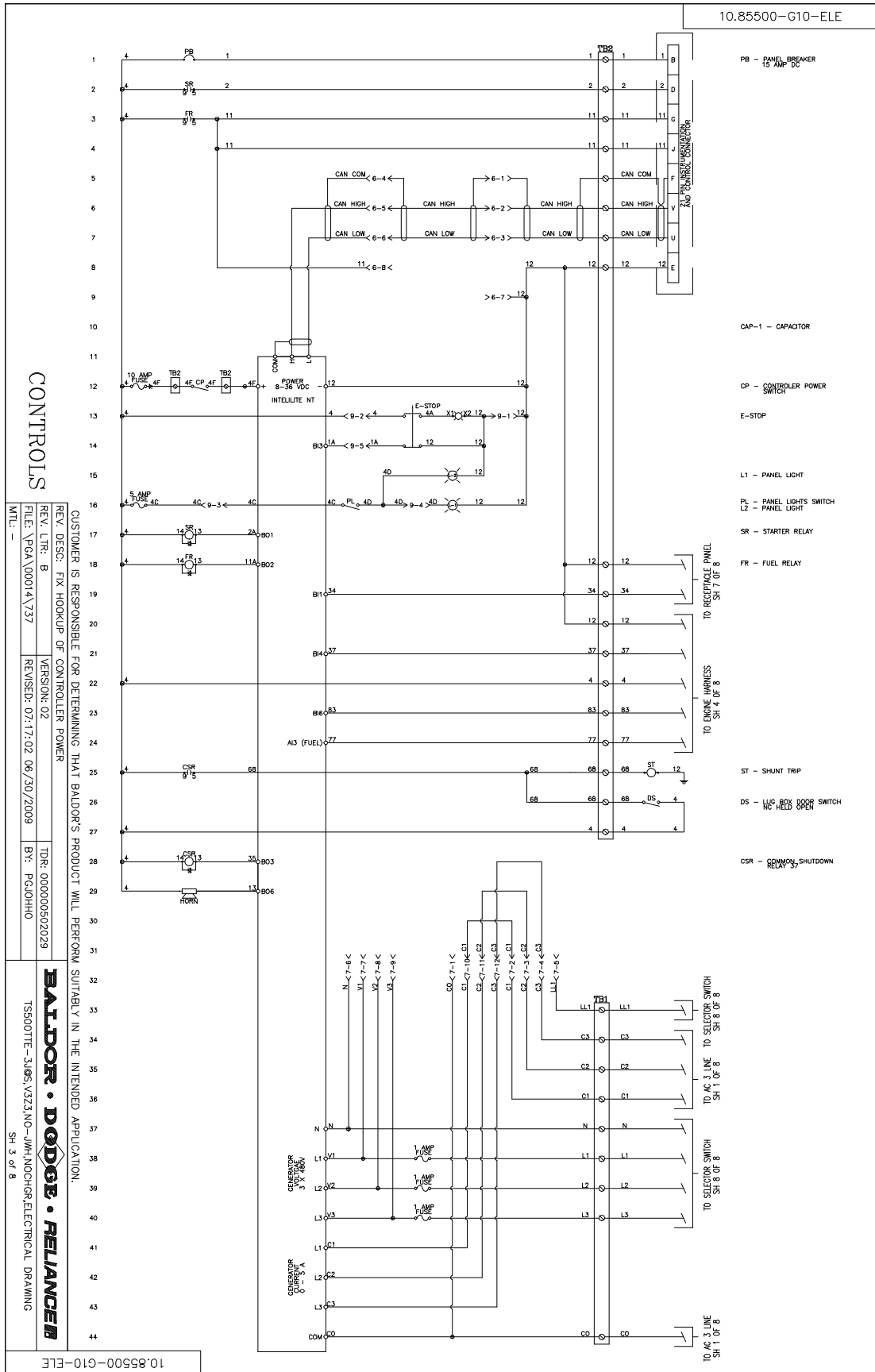
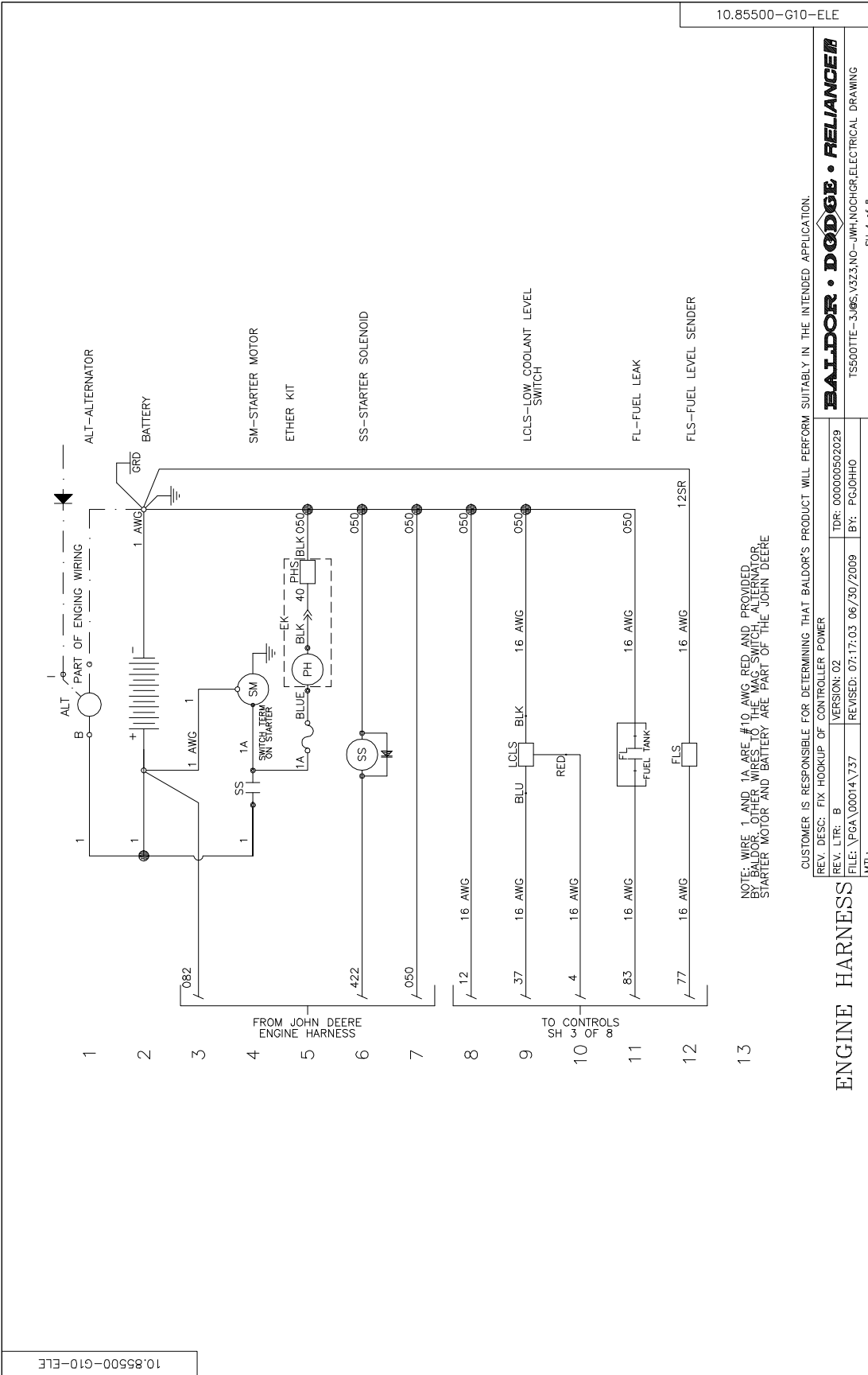

Figure A-67 TS500



CUSTOMER IS RESPONSIBLE FOR DETERMINING THAT BALDOR'S PRODUCT WILL PERFORM SUITABLY IN THE INTENDED APPLICATION.

REV. DESC: FIX HOOKUP OF CONTROLLER POWER

REV. LTR: B

FILE: \P6A\00014\737

MTL: --

VERSION: 02

TDR: 00000502029

REVISED: 07:17:03 06/30/2009

BY: PGJ0HHO

BALDOR • DODGE • RELIANCE

TS500ITE-3.0WS.V323.NO-JWH.NOCHGR.ELECTRICAL DRAWING

SH 4 of 8

ENGINE HARNESS

Figure A-68 TS500

10.85500-G10-ELE

CONNECTOR #6
9 PIN - ANALOG ENGINE GAUGES

PN NUMBER	WIRE NUMBER	NOTE
1	CC	CAN COMMON IN
2	CH	CAN HIGH IN
3	CL	CAN LOW IN
4	CC	CAN COMMON OUT
5	CH	CAN HIGH OUT
6	CL	CAN LOW OUT
7	12	-
8	11	-
9	-	-

CONNECTOR #7
12 PIN - DIGITAL PANEL

PN NUMBER	WIRE NUMBER	NOTE
1	-	-
2	C1	-
3	C2	-
4	C3	-
5	-	-
6	-	-
7	-	-
8	-	-
9	-	-
10	C1	-
11	C2	-
12	C3	-

CONNECTOR #9
9 PIN - E-STOP

PN NUMBER	WIRE NUMBER	NOTE
1	12	-
2	4	-
3	4C	-
4	4D	-
5	1A	-
6	B2	-
7	B3	-
8	-	-
9	-	-

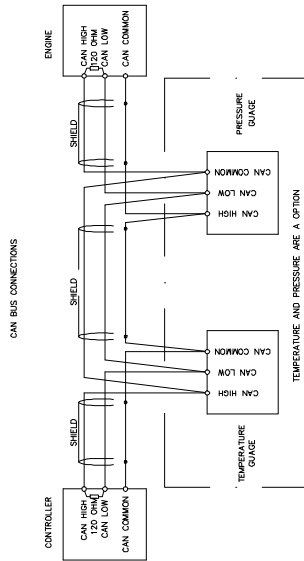

CAN BUS CABLES MUST BE CONNECTED IN SERIES, FROM ONE COMPONENT TO THE NEXT (NO STARS, NO STARS, AND NO BRANCHES) BOTH ENDS REQUIRE A 120 OHM TERMINATING RESISTOR WHICH MAY BE INTERNAL TO THE ENDING DEVICE. DO NOT ADD RESISTORS UNLESS SHOWN OR DRAWING AS ILLUSTRATED ABOVE.

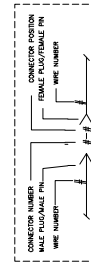

GENERAL INFORMATION

CUSTOMER IS RESPONSIBLE FOR DETERMINING THAT BALDOR'S PRODUCT WILL PERFORM SUITABLY IN THE INTENDED APPLICATION.

REV. DESC: FIX HOOKUP OF CONTROLLER POWER	TDR: 00000502029
REV. LTR: B	VERSION: 02
FILE: \PGA\00014\737	REVISED: 07:17:04 06/30/2009
MTL: -	BY: PGJOHHO

BALDOR • DODGE • RELIANCE
TS500TTE-3J06.V323.NO--JH.NDCHGR.ELECTRICAL DRAWING
SH 6 of 8

10.85500-G10-ELE

Figure A-69 TS500

10.85500-G10-ELE

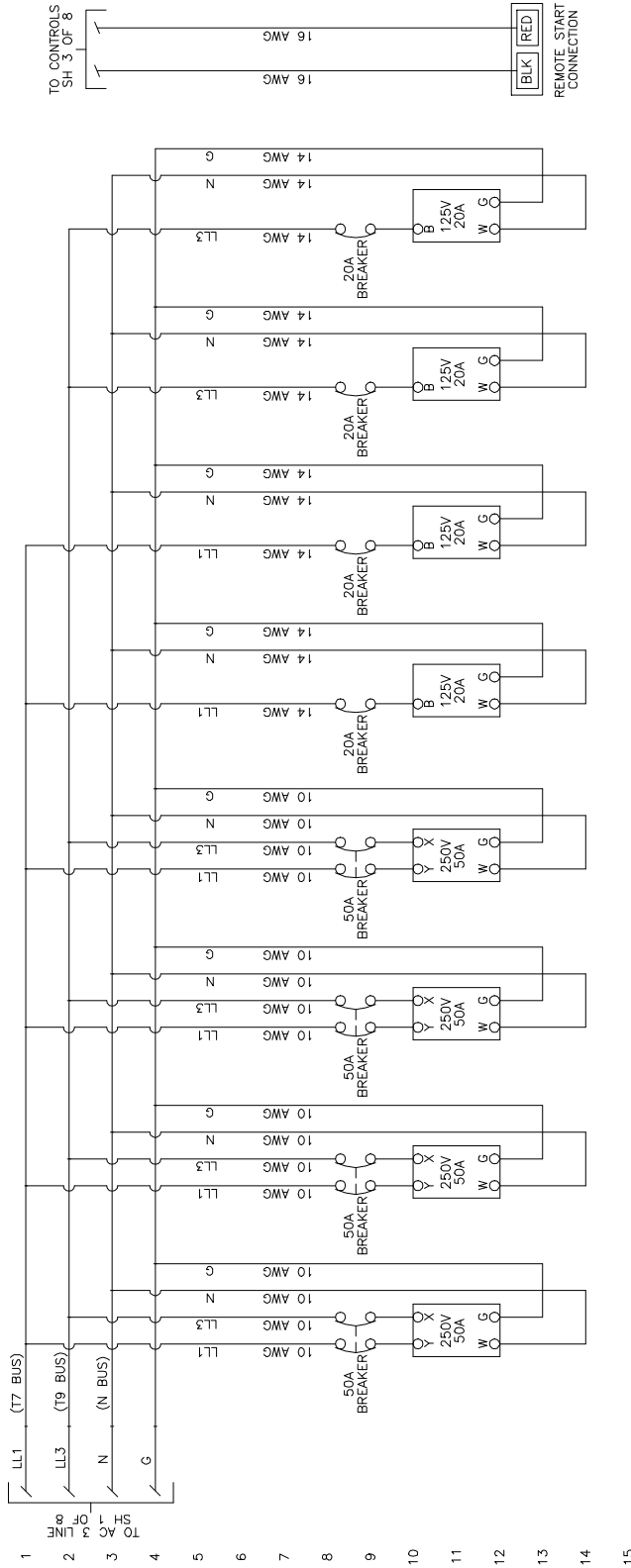

10.85500-G10-ELE

CUSTOMER IS RESPONSIBLE FOR DETERMINING THAT BALDOR'S PRODUCT WILL PERFORM SUITABLY IN THE INTENDED APPLICATION.

REV. DESC: FIX HOOKUP OF CONTROLLER POWER		BALDOR • DODGE • RELIANCE	
REV. LTR: B	VERSION: 02	TS500ITE-3.0WS.V3Z3.NO-JWH.NOCHGR.ELECTRICAL DRAWING	
FILE: \P6A\00014\737	REVISED: 07:17:04_06/30/2009	BY: PGJHHO	SH 7 of 8
MTL: -			

RECEPTACLE PANEL

Figure A-70 TS500

10.85500-G10-ELE

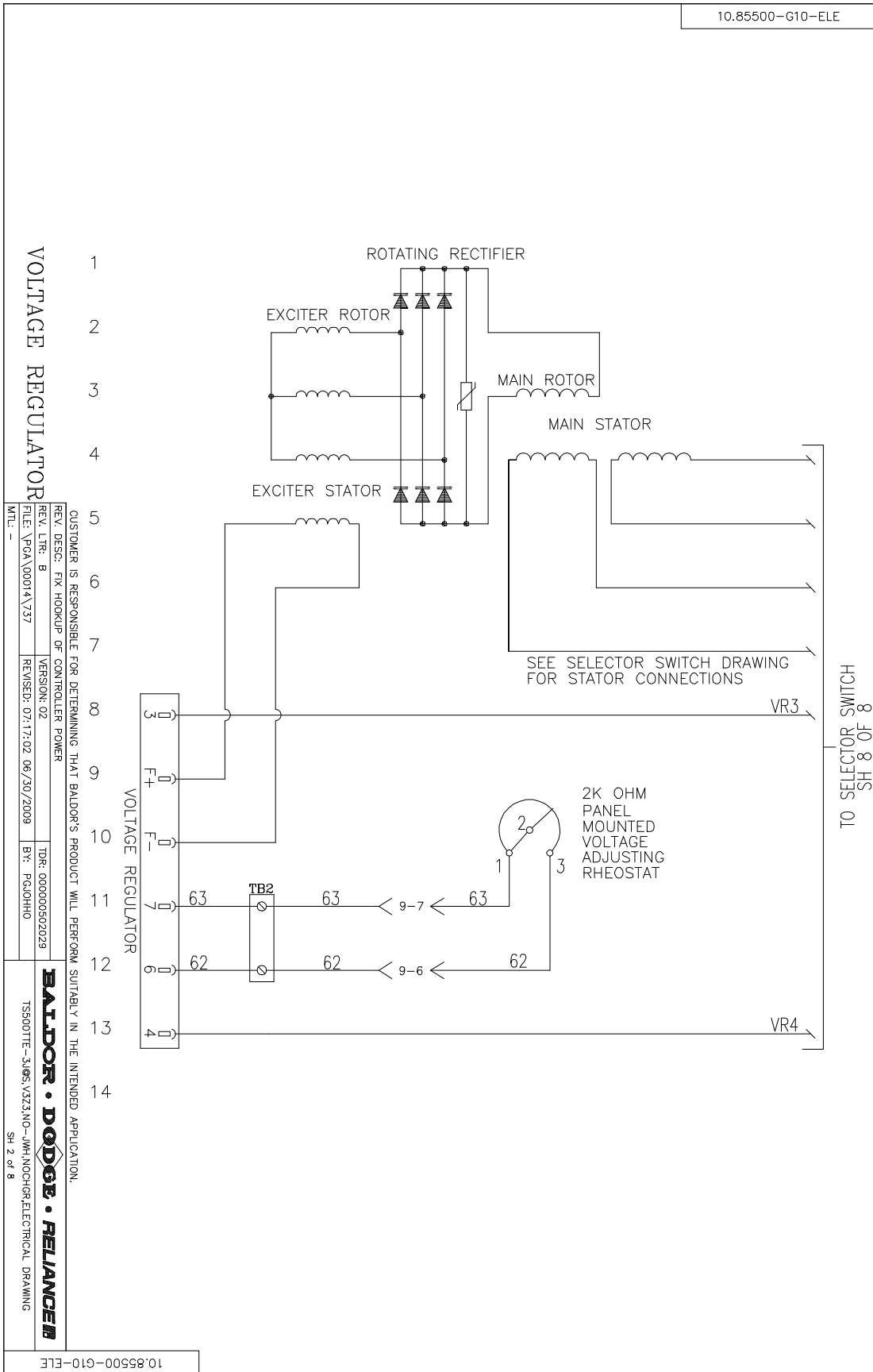
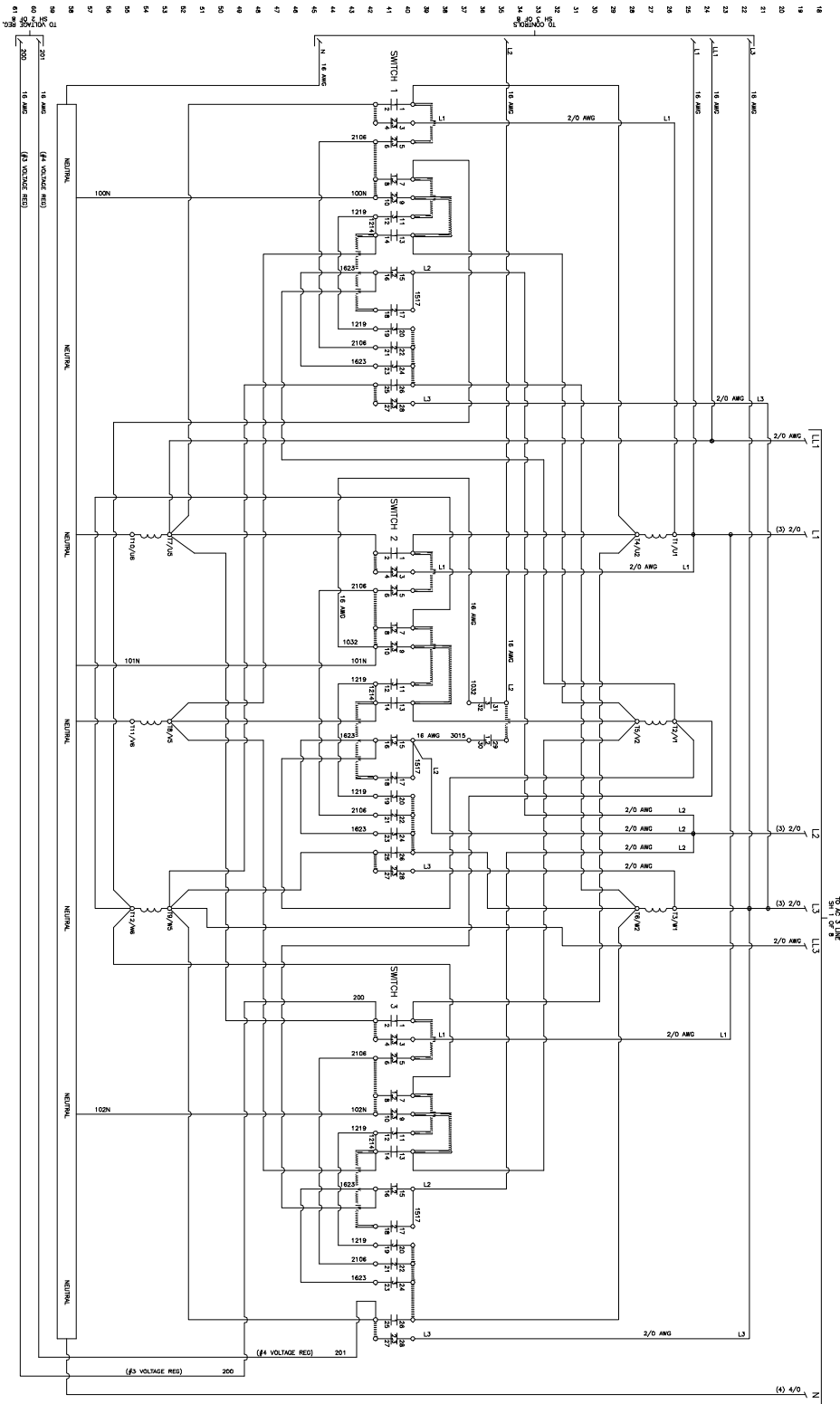

Figure A-71 TS500

10.85500-G10-ELE

All Wire 1/0AWG High Heat
 Unless Otherwise Noted.
 All 2/0AWG is High Heat. SELECTOR SWITCH



CUSTOMER IS RESPONSIBLE FOR DETERMINING THAT BALDOR'S PRODUCT WILL PERFORM SUITABLY IN THE INTENDED APPLICATION.

REV. DESG: FIX HOOKUP OF CONTROLLER POWER	VERSION: 02	TOR: 000000502029
REV. LTR: B	REVISION: 02	BY: PGIJHD
FILE: \PGA\00014\737	REVISED: 07:17:05 06/30/2009	
MTL: -		

BALDOR • DODGE • RELIANCE
 TS500TTE-3J08S.V3Z3.NO-JWH.N0CHGR.ELECTRICAL DRAWING
 SH 8 of 8

10.85500-G10-ELE

Baldor District Offices

UNITED STATES

ARIZONA

PHOENIX
4211 S 43RD PLACE
PHOENIX, AZ 85040
PHONE: 602-470-0407
FAX: 602-470-0464

ARKANSAS

CLARKSVILLE
1001 COLLEGE AVE.
CLARKSVILLE, AR 72830
PHONE: 479-754-9108
FAX: 479-754-9205

CALIFORNIA

LOS ANGELES
6480 FLOTILLA
COMMERCE, CA 90040
PHONE: 323-724-6771
FAX: 323-721-5859

HAYWARD

21056 FORBES STREET
HAYWARD, CA 94545
PHONE: 510-785-9900
FAX: 510-785-9910

COLORADO

DENVER
3855 FOREST STREET
DENVER, CO 80207
PHONE: 303-623-0127
FAX: 303-595-3772

CONNECTICUT

WALLINGFORD
65 SOUTH TURNPIKE ROAD
WALLINGFORD, CT 06492
PHONE: 203-269-1354
FAX: 203-269-5485

FLORIDA

**TAMPA/PUERTO RICO/
VIRGIN ISLANDS**
3906 EAST 11TH AVENUE
TAMPA, FL 33605
PHONE: 813-248-5078
FAX: 813-247-2984

GEORGIA

ATLANTA
62 TECHNOLOGY DR.
ALPHARETTA, GA 30005
PHONE: 770-772-7000
FAX: 770-772-7200

ILLINOIS

CHICAGO
4 SAMMONS COURT
BOLINGBROOK, IL 60440
PHONE: 630-296-1400
FAX: 630-226-9420

INDIANA

INDIANAPOLIS
5525 W. MINNESOTA STREET
INDIANAPOLIS, IN 46241
PHONE: 317-246-5100
FAX: 317-246-5110

IOWA

DES MOINES
1800 DIXON STREET, SUITE C
DES MOINES, IA 50316
PHONE: 515-263-6929
FAX: 515-263-6515

MARYLAND

BALTIMORE
6660 SANTA BARBARA RD.
SUITE 22-24
ELKRIDGE, MD 21075
PHONE: 410-579-2135
FAX: 410-579-2677

MASSACHUSETTS

BOSTON
6 PULLMAN STREET
WORCESTER, MA 01606
PHONE: 508-854-0708
FAX: 508-854-0291

MICHIGAN

DETROIT
5993 PROGRESS DRIVE
STERLING HEIGHTS, MI 48312
PHONE: 586-978-9800
FAX: 586-978-9969

MINNESOTA

MINNEAPOLIS
21080 134TH AVE. NORTH
ROGERS, MN 55374
PHONE: 763-428-3633
FAX: 763-428-4551

MISSOURI

ST LOUIS
422 INDUSTRIAL DRIVE
MARYLAND HEIGHTS, MO 63043
PHONE: 314-298-1800
FAX: 314-298-7660

KANSAS CITY

1501 BEDFORD AVENUE
NORTH KANSAS CITY, MO 64116
PHONE: 816-587-0272
FAX: 816-587-3735

NEW YORK

AUBURN
ONE ELLIS DRIVE
AUBURN, NY 13021
PHONE: 315-255-3403
FAX: 315-253-9923

NORTH CAROLINA

GREENSBORO
1220 ROTHERWOOD ROAD
GREENSBORO, NC 27406
PHONE: 336-272-6104
FAX: 336-273-6628

OHIO

CINCINNATI
2929 CRESCENTVILLE ROAD
WEST CHESTER, OH 45069
PHONE: 513-771-2600
FAX: 513-772-2219

CLEVELAND

8929 FREEWAY DRIVE
MACEDONIA, OH 44056
PHONE: 330-468-4777
FAX: 330-468-4778

OKLAHOMA

TULSA
7170 S. BRADEN, SUITE 140
TULSA, OK 74136
PHONE: 918-366-9320
FAX: 918-366-9338

OREGON

PORTLAND
20393 SW AVERY COURT
TUALATIN, OR 97062
PHONE: 503-691-9010
FAX: 503-691-9012

PENNSYLVANIA

PHILADELPHIA
1035 THOMAS BUSCH
MEMORIAL HIGHWAY
PENNSAUKEN, NJ 08110
PHONE: 856-661-1442
FAX: 856-663-6363

PITTSBURGH

159 PROMINENCE DRIVE
NEW KENSINGTON, PA 15068
PHONE: 724-889-0092
FAX: 724-889-0094

TENNESSEE

MEMPHIS
4000 WINCHESTER ROAD
MEMPHIS, TN 38118
PHONE: 901-365-2020
FAX: 901-365-3914

TEXAS

DALLAS
3040 QUEBEC
DALLAS, TX 75247
PHONE: 214-634-7271
FAX: 214-634-8874

HOUSTON

10355 W. LITTLE YORK RD.
SUITE 300
HOUSTON, TX 77041
PHONE: (281) 977-6500
FAX: (281) 977-6510

UTAH

SALT LAKE CITY
2230 SOUTH MAIN STREET
SALT LAKE CITY, UT 84115
PHONE: 801-832-0127
FAX: 801-832-8911

WISCONSIN

MILWAUKEE
1960 S. CALHOUN ROAD
NEW BERLIN, WI 53151
PHONE: 262-784-5940
FAX: 262-784-1215

INTERNATIONAL SALES

FORT SMITH, AR
P.O. BOX 2400
FORT SMITH, AR 72902
PHONE: 479-646-4711
FAX: 479-648-5895

CANADA

EDMONTON, ALBERTA
4053-92 STREET
EDMONTON, ALBERTA T6E 6R8
PHONE: 780-434-4900
FAX: 780-438-2600

TORONTO

OAKVILLE, ONTARIO
2750 COVENTRY ROAD
OAKVILLE, ONTARIO L6H 6R1
PHONE: 905-829-3301
FAX: 905-829-3302

MONTREAL, QUEBEC

5155, J.A. BOMBARDIER
ST-HUBERT (QUEBEC) CANADA
J3Z 1G4
PHONE: 514-933-2711
FAX: 514-933-8639

VANCOUVER, BRITISH COLUMBIA

1538 KEBET WAY
PORT COQUITLAM,
BRITISH COLUMBIA V3C 5M5
PHONE 604-421-2822
FAX: 604-421-3113

WINNIPEG, MANITOBA

54 PRINCESS STREET
WINNIPEG, MANITOBA R3B 1K2
PHONE: 204-942-5205
FAX: 204-956-4251

AUSTRALIA

UNIT 3, 6 STANTON ROAD
SEVEN HILLS, NSW 2147, AUSTRALIA
PHONE: (61) (2) 9674 5455
FAX: (61) (2) 9674 2495

UNIT 8, 5 KELLETTS ROAD
ROWVILLE, VICTORIA, 3178 AUSTRALIA
PHONE: (61) (3) 9753 4355
FAX: (61) (3) 9753 4366

EL SALVADOR

RESIDENCIAL PINARES DE SUIZA
POL. 15 #44,
NVA. SAN SALVADOR, EL SALVADOR
PHONE: +503 2288-1519
FAX: +503 2288-1518

CHILE

LUIS THAYER OJEDA 166,
OF 402 - PROVIDENCIA
SANTIAGO, CHILE
PHONE: +56 2 816 9900

CHINA

160 SONG SHENG ROAD
SONGJIANG INDUSTRY ZONE
SHANGHAI 201613, CHINA
PHONE: +86 21 5760 5335
FAX: +86 21 5760 5336

GERMANY

DIESELSTRASSE 22
D-85551 KIRCHHEIM
MUNICH, GERMANY
PHONE: +49 89 90 50 5080
FAX: +49 89 90 50 8492

INDIA

14, COMMERCE AVENUE
MAHAGANESH COLONY
PAUD ROAD
PUNE - 411038
MAHARASHTRA, INDIA
PHONE: +91 20 25 45 27 17 / 18
FAX: +91 20 25 45 27 19

INDONESIA

TALAVERA OFFICE PARK,
28TH FLOOR, SUITE M18
JI. T.B. SIMATUPANG, KAV. 22-26
JAKARTA 12430, INDONESIA
PHONE: +62 21 7599 9879
FAX: +62 21 7599 9878

ITALY

BALDOR ASR AG
SUCCURSALE DI MENDRISIO
VIA BORROMINI, 20A
CH-6850 MENDRISIO
SWITZERLAND
PHONE: 0041 91 640 99 50
FAX: 0041 91 630 26 33

JAPAN

DIA BLDG 802,
2-21-1 TSURUYA-CHO,
KANAGAWA-KU
YOKOHAMA, 221-0835, JAPAN
PHONE: 81-45-412-4506
FAX: 81-45-412-4507

MEXICO

LEON, GUANAJUATO
KM. 2.0 BLVD. AEROPUERTO
LEÓN 37545, GUANAJUATO, MÉXICO
PHONE: +52 477 761 2030
FAX: +52 477 761 2010

MIDDLE EAST & NORTH AFRICA

YSE INTERNATIONAL CORP.
P. O. BOX 5618
BUFFALO GROVE, IL 60089-5618
PHONE: 847 590 5547
FAX: 847 590 5587

PANAMA

AVE. RICARDO J. ALFARO
EDIFICIO SUN TOWERS MALL
PISO 2, LOCAL 55
CIUDAD DE PANAMÁ, PANAMÁ
PHONE: +507 236-5155
FAX: +507 236-0591

SINGAPORE

18 KAKI BUKIT ROAD 3, #03-09
ENTREPRENEUR BUSINESS CENTRE
SINGAPORE 415978
PHONE: (65) 6744 2572
FAX: (65) 6747 1708

SWITZERLAND

POSTFACH 73
SCHUTZENSTRASSE 59
CH-8245 FEUERTHALEN
SWITZERLAND
PHONE: +41 52 647 4700
FAX: +41 52 659 2394

TAIWAN

1F, NO 126 WENSHAN 3RD STREET,
NANTUN DISTRICT,
TAICHUNG CITY 408
TAIWAN R.O.C
PHONE: (886) 4 238 04235
FAX: (886) 4 238 04463

UNITED KINGDOM

6 BRISTOL DISTRIBUTION PARK
HAWKLEY DRIVE
BRISTOL BS32 0BF U.K.
PHONE: +44 1454 850000
FAX: +44 1454 859001

VENEZUELA

AV. ROMA. QTA EL MILAGRO. URB.
CALIFORNIA NORTE
CARACAS, 1070
VENEZUELA
PHONE/FAX: +58 212 272 7343
MOBILE: +58 414 114 8623

WARNING:
CALIFORNIA PROPOSITION 65 WARNING:
Engine exhaust from this product contains chemicals known to the state of California to cause cancer, birth defects and other reproductive harm.

WARNING:
CALIFORNIA PROPOSITION 65 WARNING:
Battery posts, terminals and related accessories are known to the state of California to cause cancer, birth defects and other reproductive harm.



BALDOR®

World Headquarters
P.O. Box 2400 Fort Smith, AR 72902-2400 USA Ph: (1) 479.646.4711, Fax: (1)
479.648.5792
www.baldor.com

